



CHINMORE INDUSTRY CO.,LTD

Specification

1. Product Type: GPS/GLONASS & LTE

Adhesive Mount Antenna for cars

2. Chinmore's No: R30 series

3. Frequency for GPS: 1575.42 MHz

Frequency for GLONASS: 1602 MHz

Frequency for LTE: 824~960/1710~2170/2700 MHz

4. Cable RG-174 3m with SMA (M) ST connector

5. 3M sticker

✧RoHS Compliant

✧ISO 9001 & ISO 14001

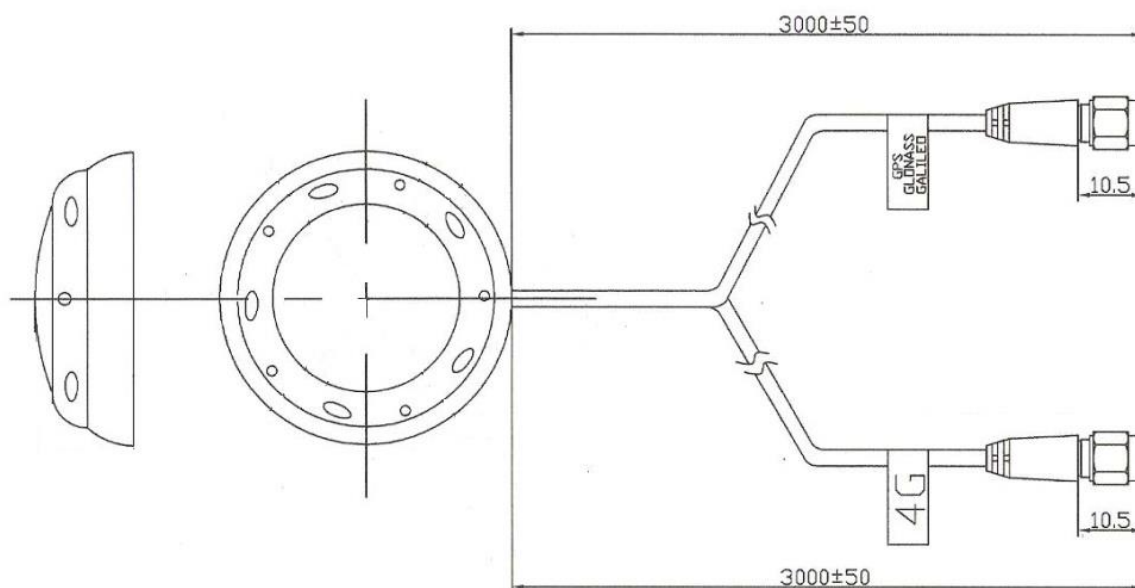

ELECTRICAL

Frequency (MHz)	Return Loss (dB)	VSWR	Efficiency (%)	Gain (dB)
1575.42	-13.45	1.53	-----	29.26
1602	-14.81	1.50	-----	25.37
824	-13.52	1.58	27.35	-1.57
880	-12.62	1.60	36.22	-0.53
960	-10.13	1.98	24.83	-1.3
1710	-14.61	1.49	45.5	2.44
1880	-18.76	1.26	73.11	5.16
2170	-16.25	1.36	57.54	3.61
2700	-12.59	1.60	38.55	3.05

1. TEST REPORT(GPS/GLONASS)

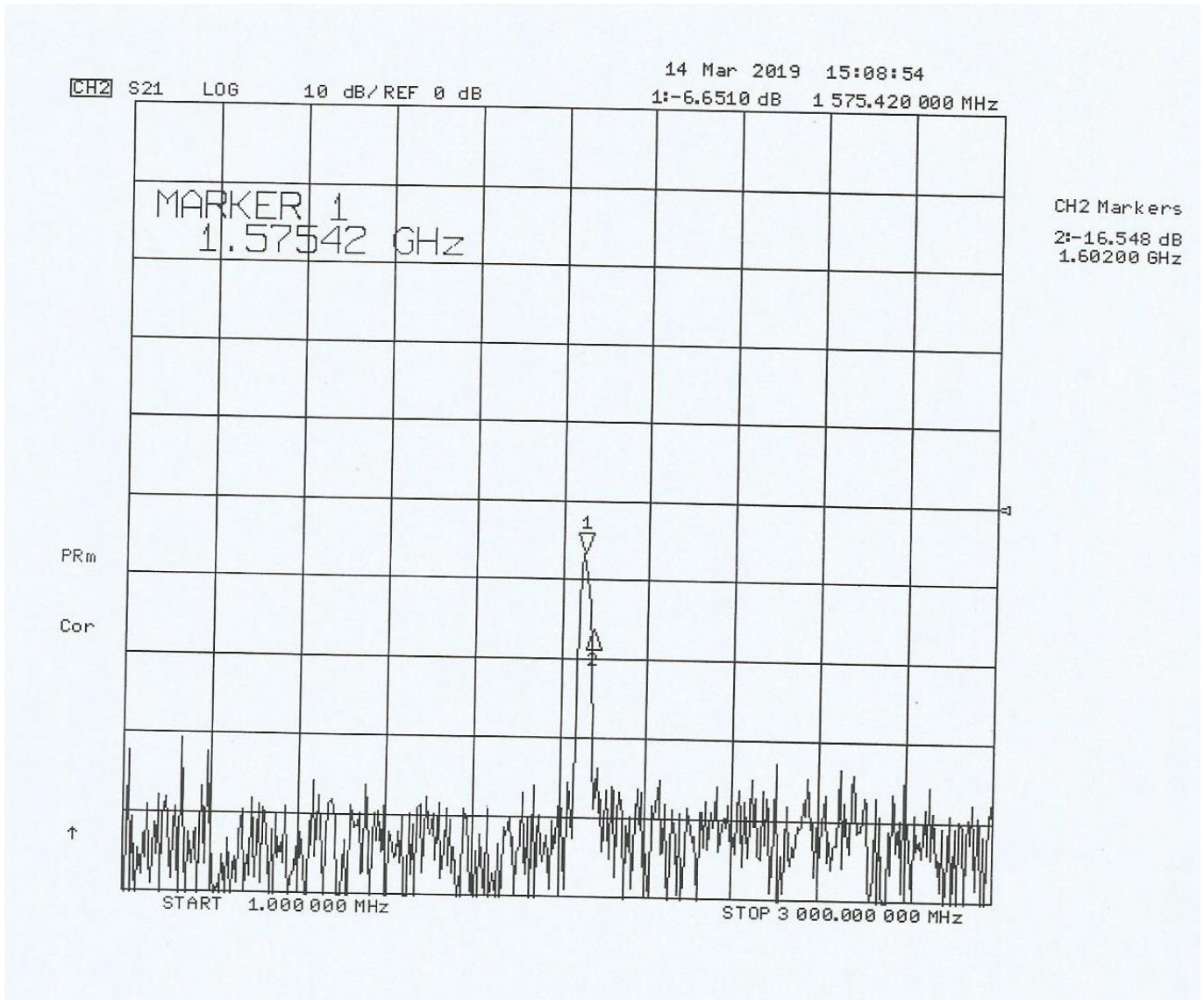

Tr1 S11 Log Mag 10.00dB/ Ref 0.000dB [RO]

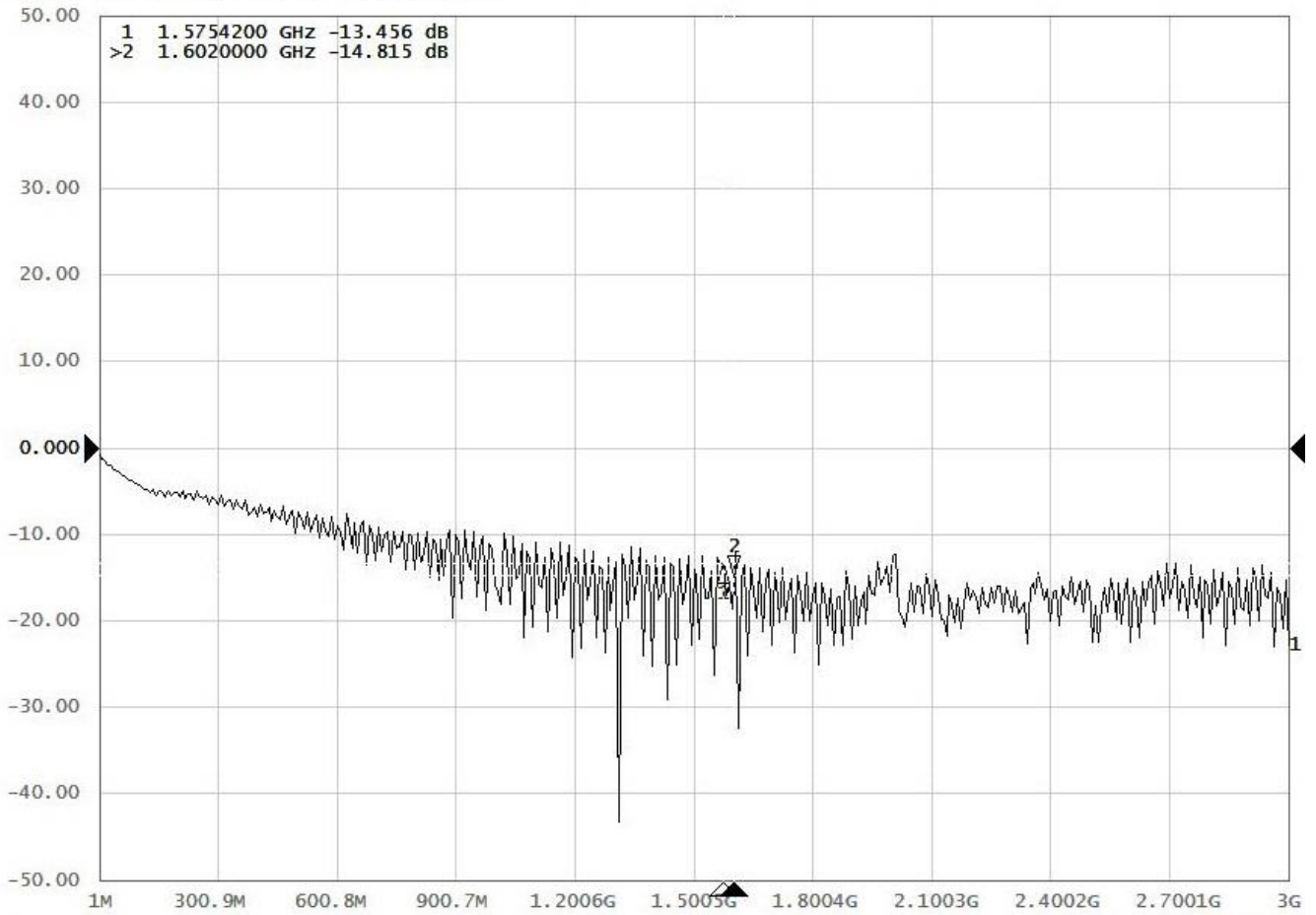

Tr1 S11 SWR 1.000/ Ref 1.000 [RO]

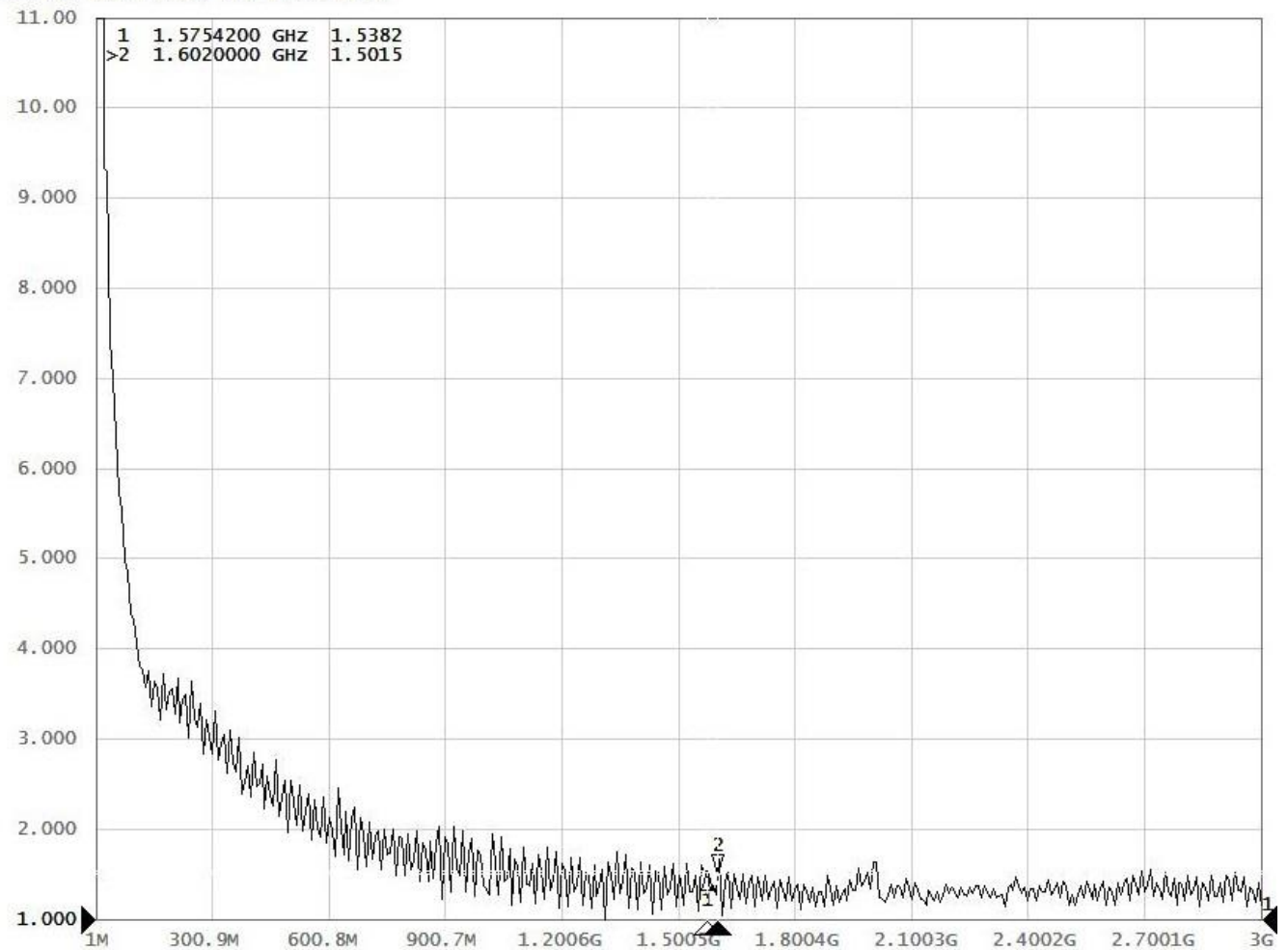

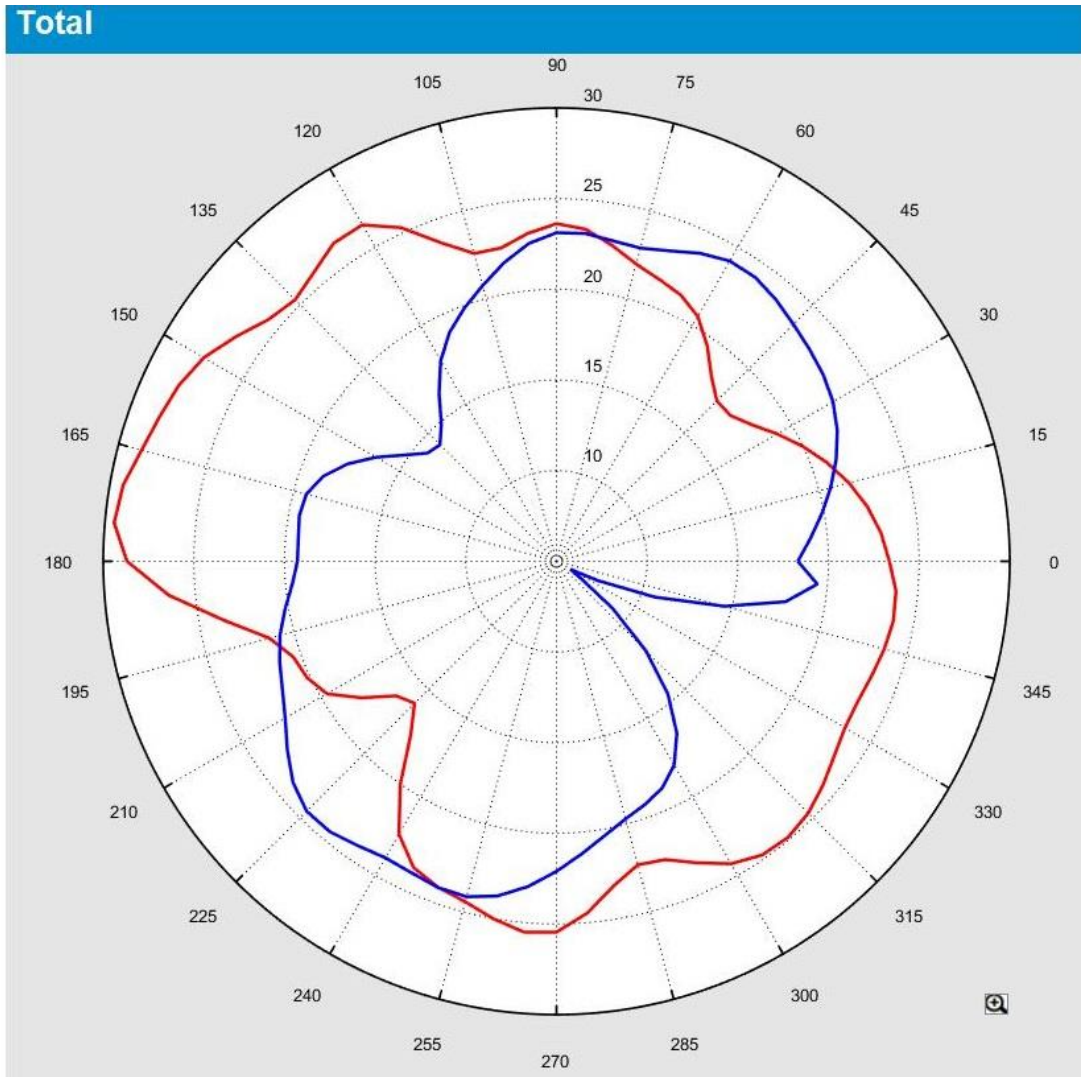

Total_Efficiency (%)

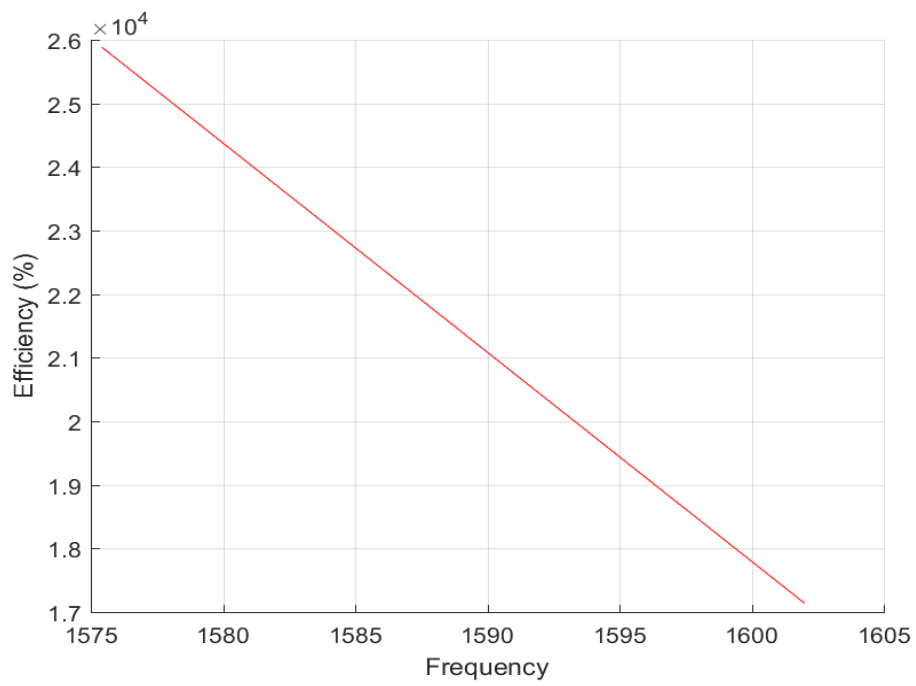

Total_Gain (dBi)

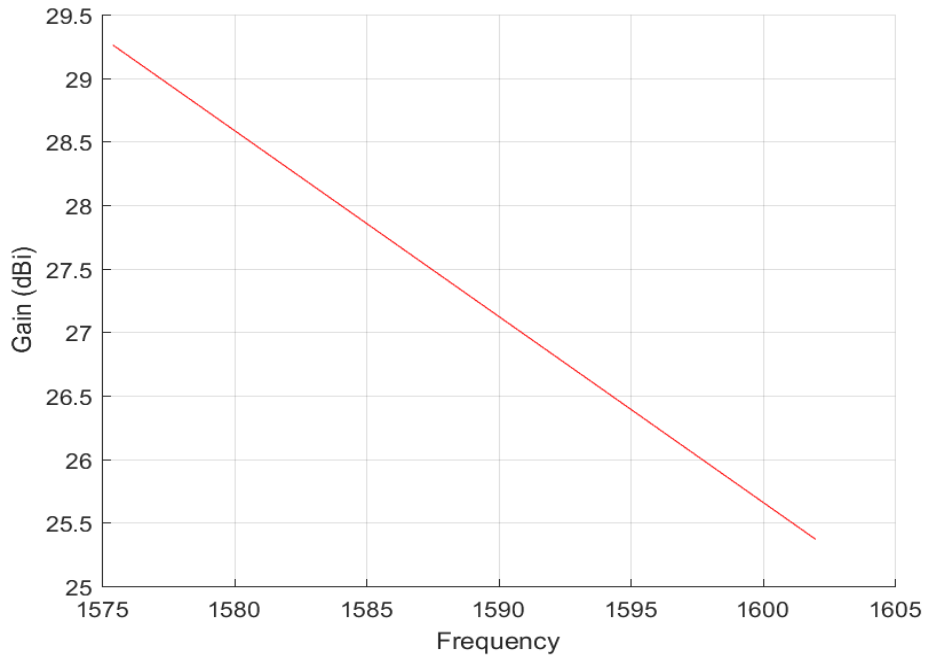

Total_3D_Side View 1_1.57542GHz

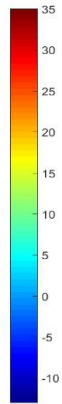
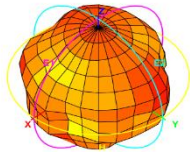

Total_3D_Side View 1_1.602GHz

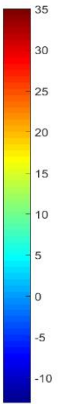
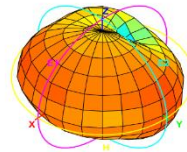

TEST REPORT(LTE)

Tr1 S11 Log Mag 10.00dB/ Ref 0.000dB [RO]

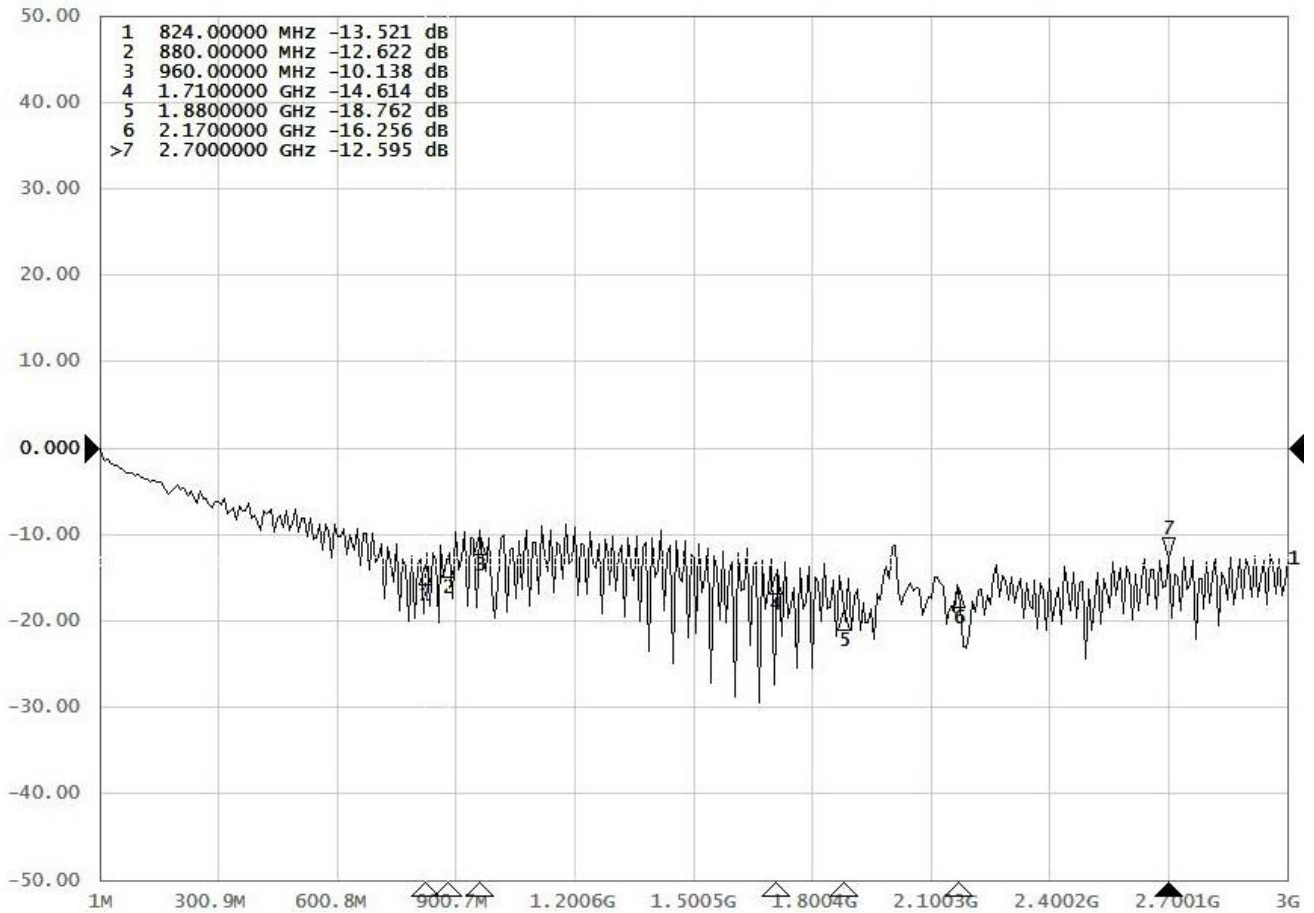

Tr1 S11 SWR 1.000/ Ref 1.000 [RO]

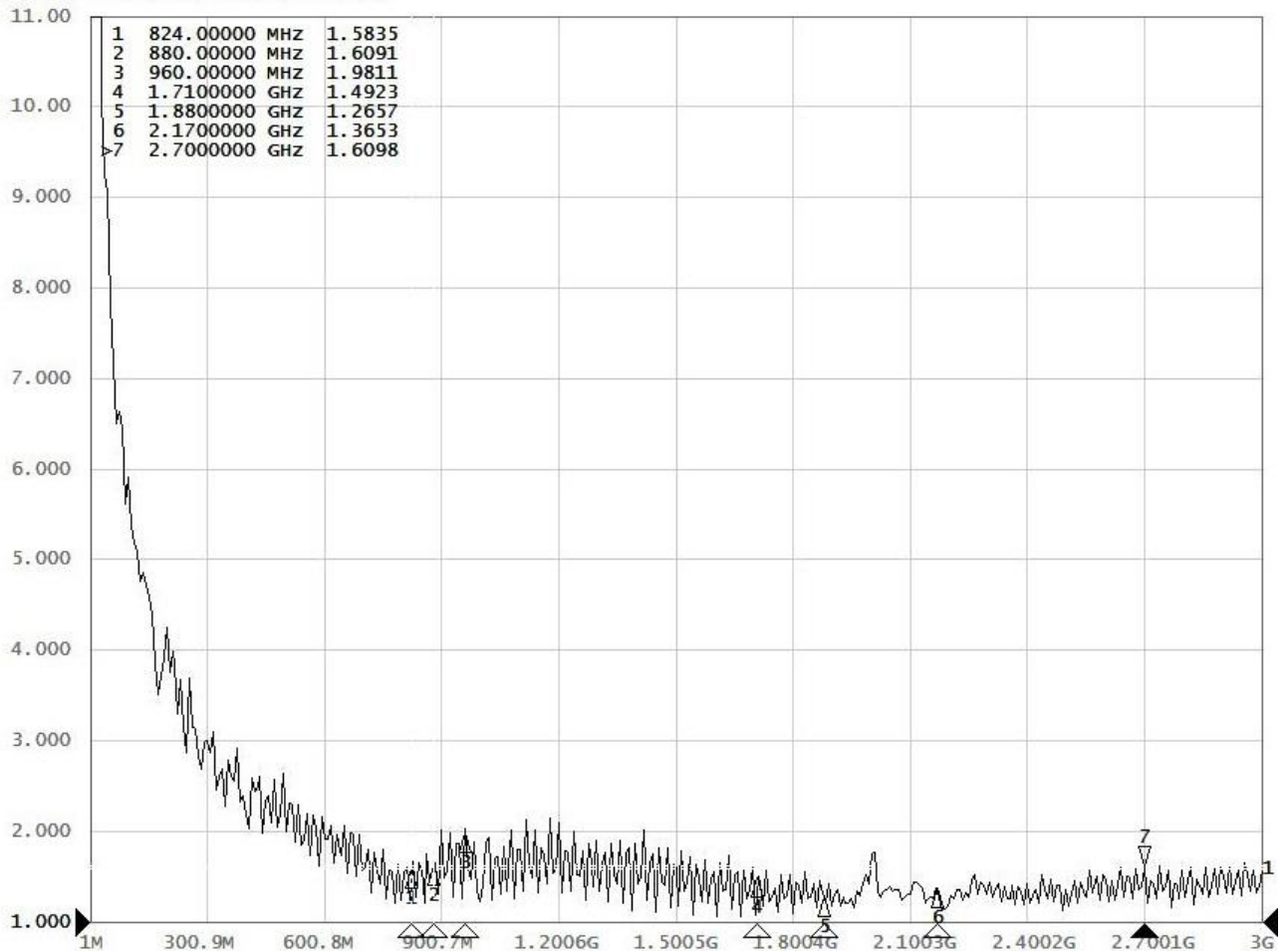

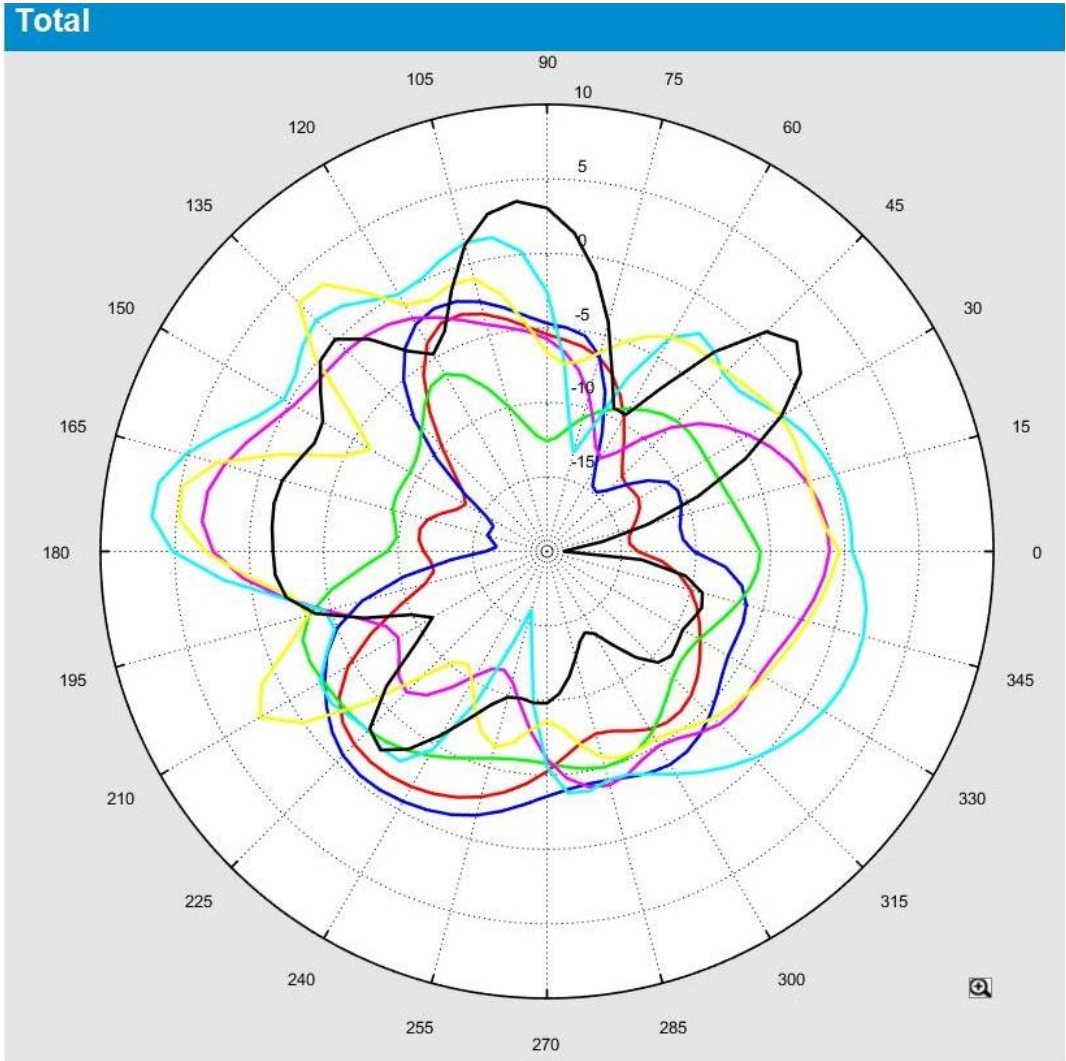

Total_Efficiency (%)

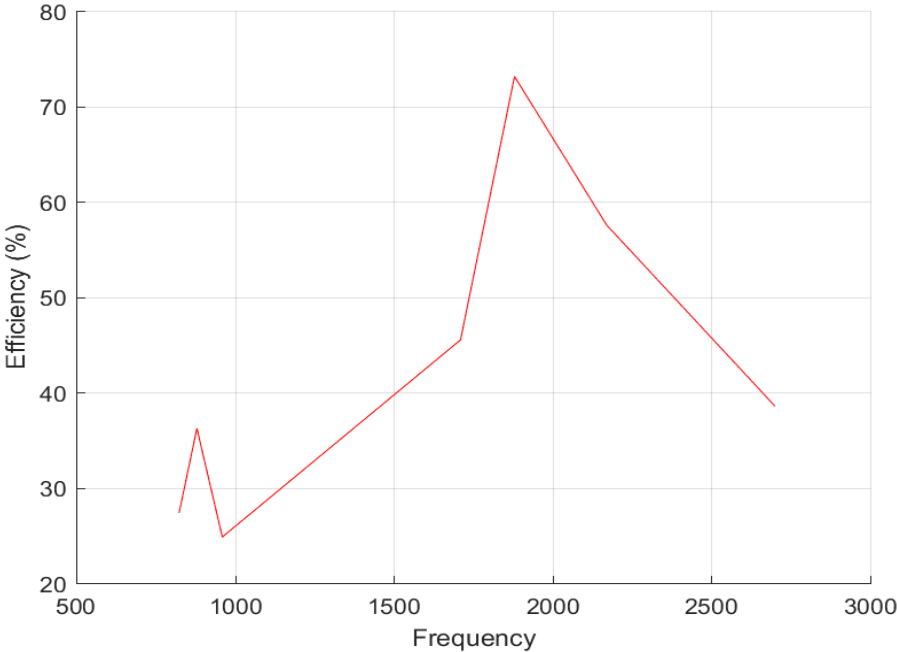

Total_Gain (dBi)

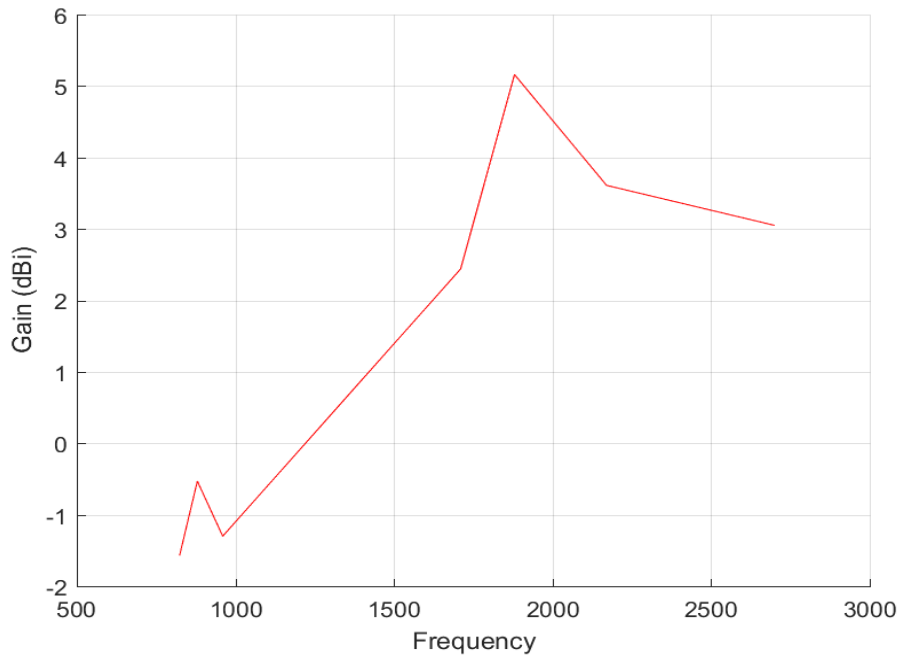

Total_3D_Side View 1_824MHz

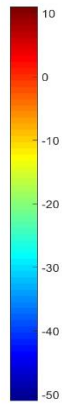
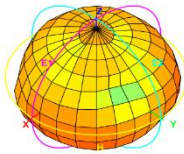

Total_3D_Side View 1_880MHz

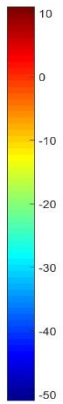
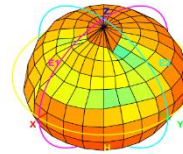

Total_3D_Side View 1_960MHz

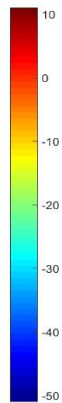
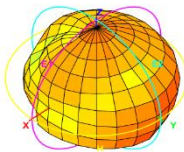

Total_3D_Side View 1_1.71GHz

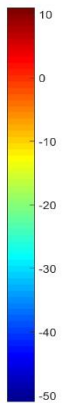
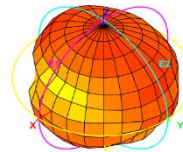

Total_3D_Side View 1_1.88GHz

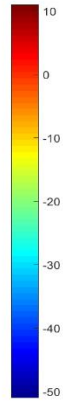
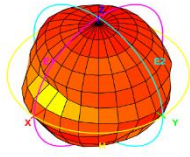

Total_3D_Side View 1_2.17GHz

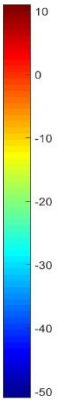
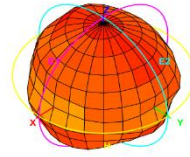

Total_3D_Side View 1_2.7GHz

