



CHINMORE INDUSTRY CO.,LTD

Specification

1. Rubber Stubby Antenna for 3G/GSM
2. *Chinmore's* No: EM-W79B-7ANT-108
3. Frequency: 800/900/1800/1900/2100 MHz
4. Connector: 90° Hinged R/A FME F
5. Operating Temperature Range: -20°C~+60°C
6. Storage Temperature Range: -30°C~+70°C

✧RoHS Compliant

✧ISO 9001 & ISO 14001

NO.	NAME	FINISH	Q, TY
01	Core tube	Black	01
02	Fixed upper	Black	01
03	Fixed beneath	Black	01
04	RIVET	Chrom plating	02
05	FME (Female)	Nickel plating	01

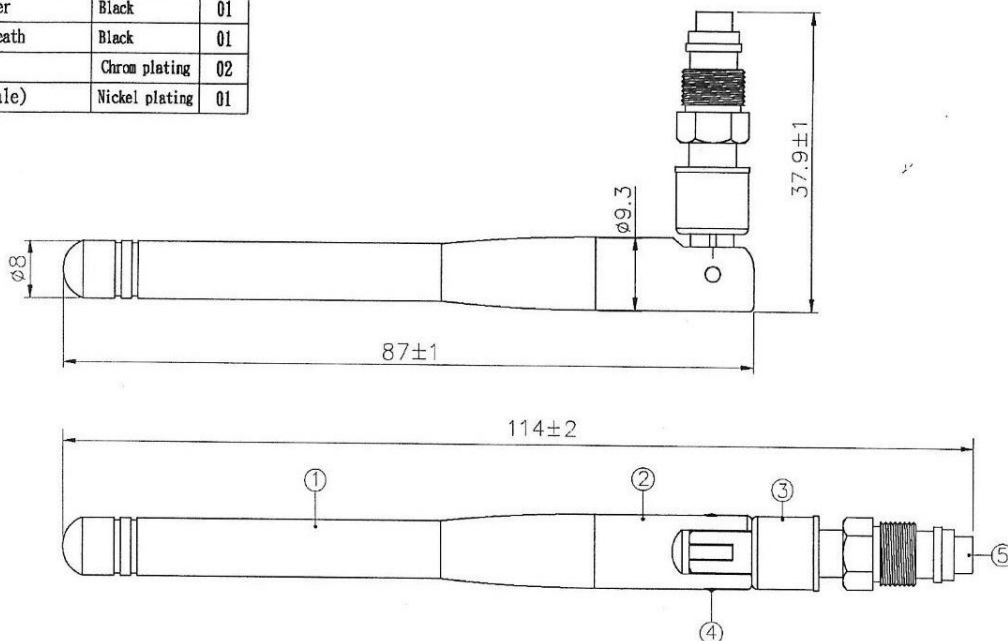

EM-W79B-7ANT-108

 Third angle projection 竣茂工業有限公司	CUSTOMER'S	MODEL	PARTS NUMBER	FREQUENCY	UNIT	SCALE	DATE	VERSION
	TOLERANCE	X. XX±0. 15	NAME	PARTS NUMBER	800/900/1800/1900/2100MHz	M/M		20091030
SURFACE ROUGHNESS	\sqrt{S}	APPEARANCE	EA-79B-7	APPROVED	CHECKED	DRAWING	DESIGNED	

98.12.30
陳俊帆

12/30

Frequency (MHz)	Return Loss (dB)	VSWR	Efficiency (%)	Gain (dBi)
824 MHz	-9.21	2.04	21.38	-3.64
960 MHz	-7.68	2.43	31.62	-0.98
1710 MHz	-7.23	2.52	68.39	1.46
1990 MHz	-5.03	3.57	17.26	-4.33

Test Data(Return Loss & VSWR)

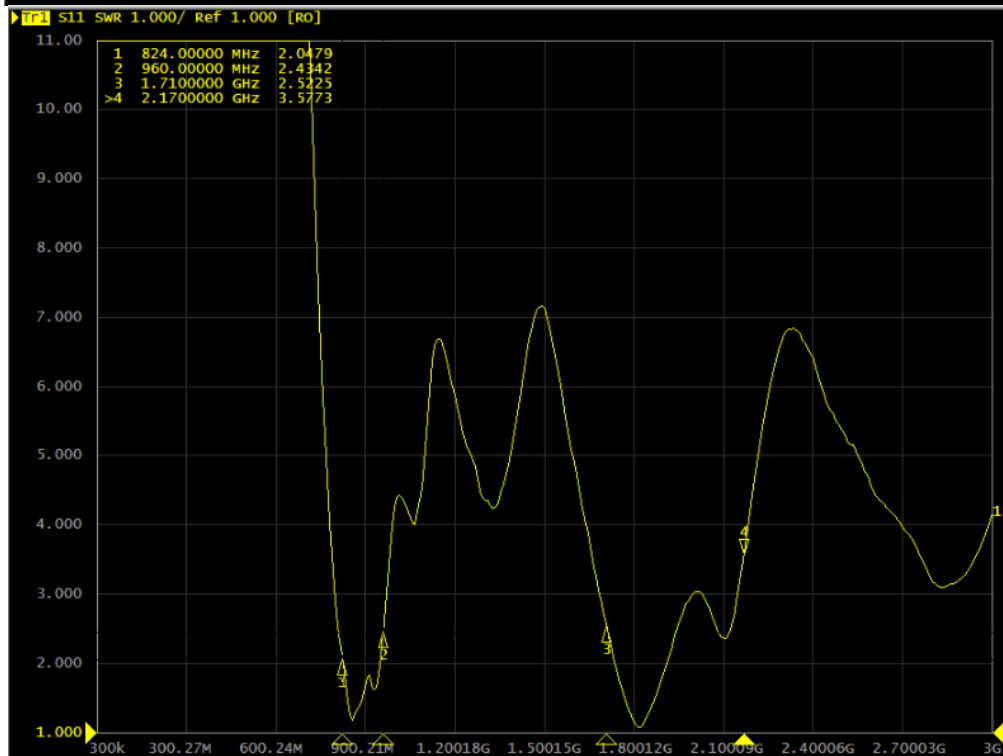
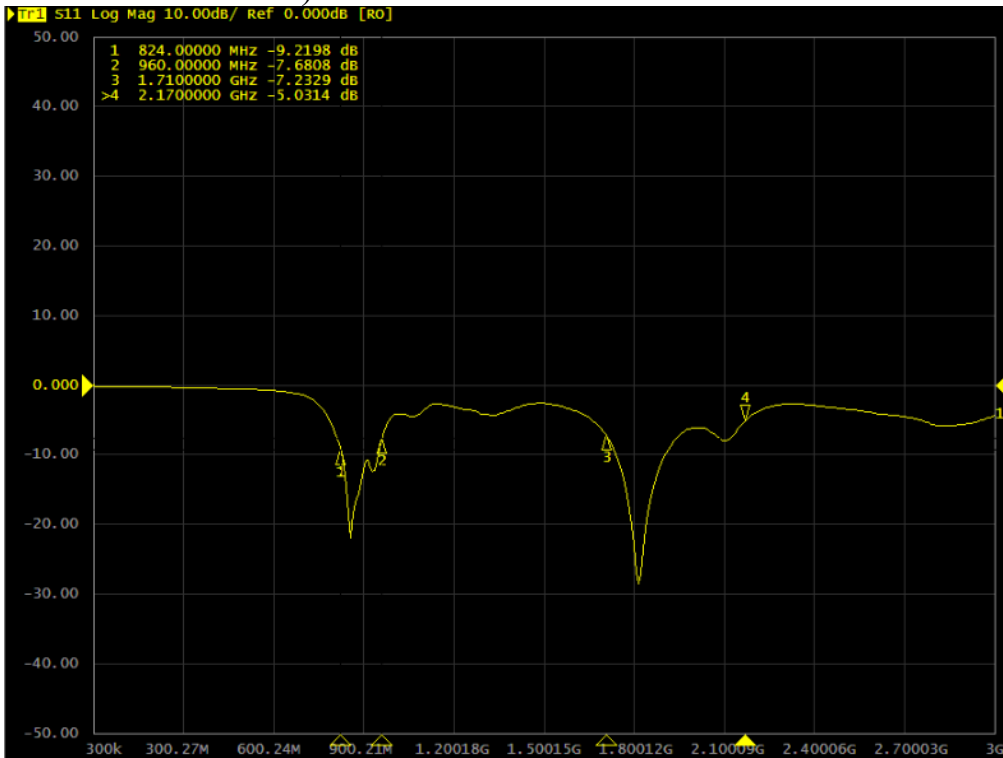

3D Test Photo

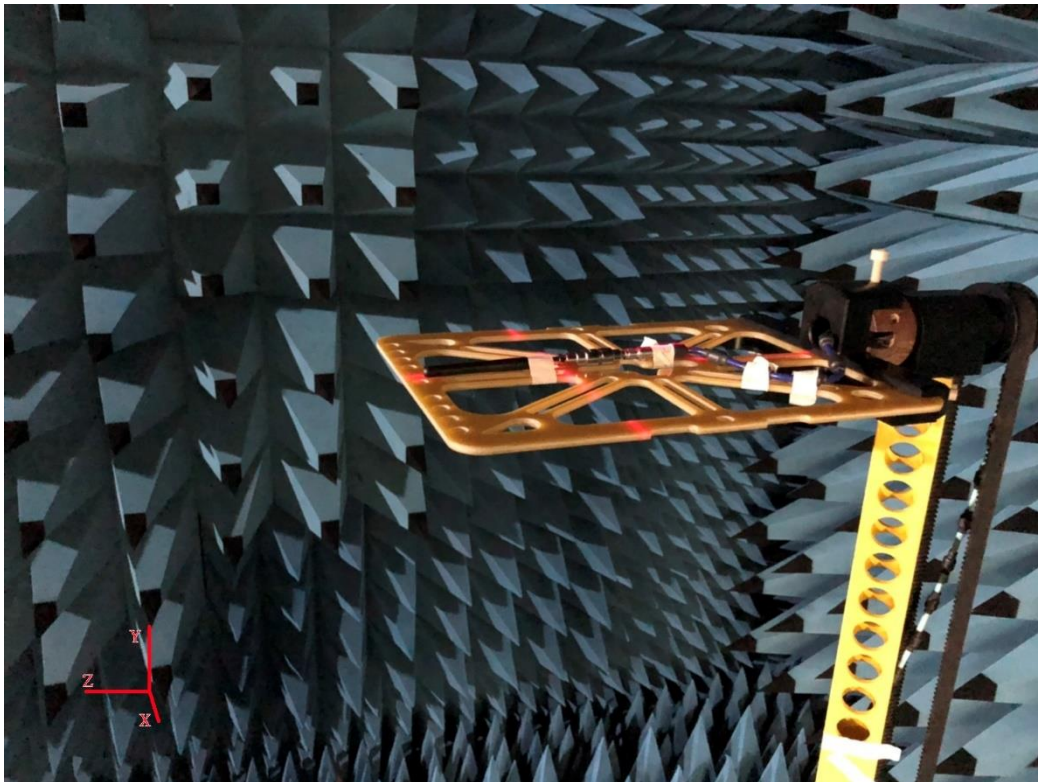

3D Test Data

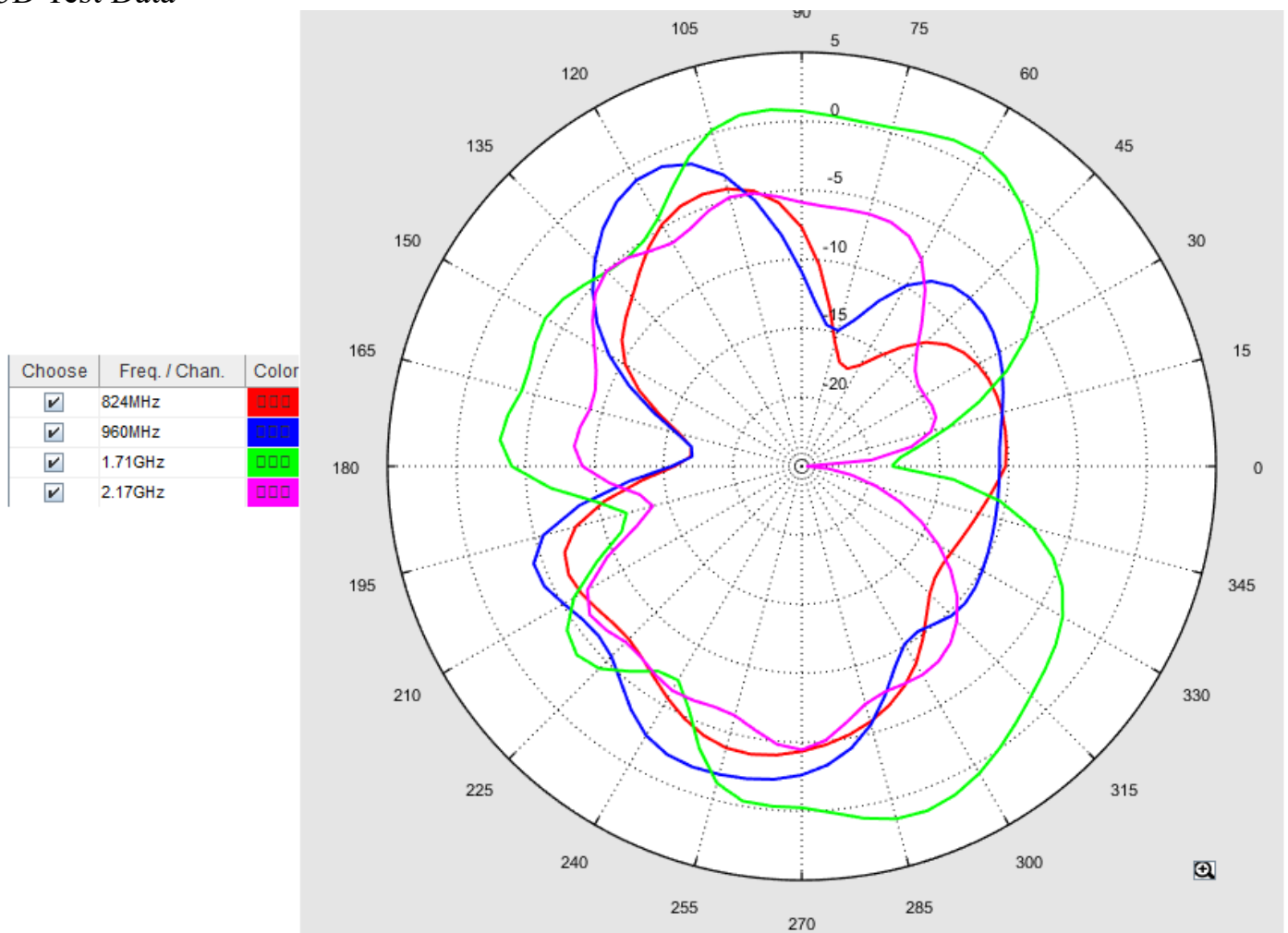

Total_Efficiency (%)

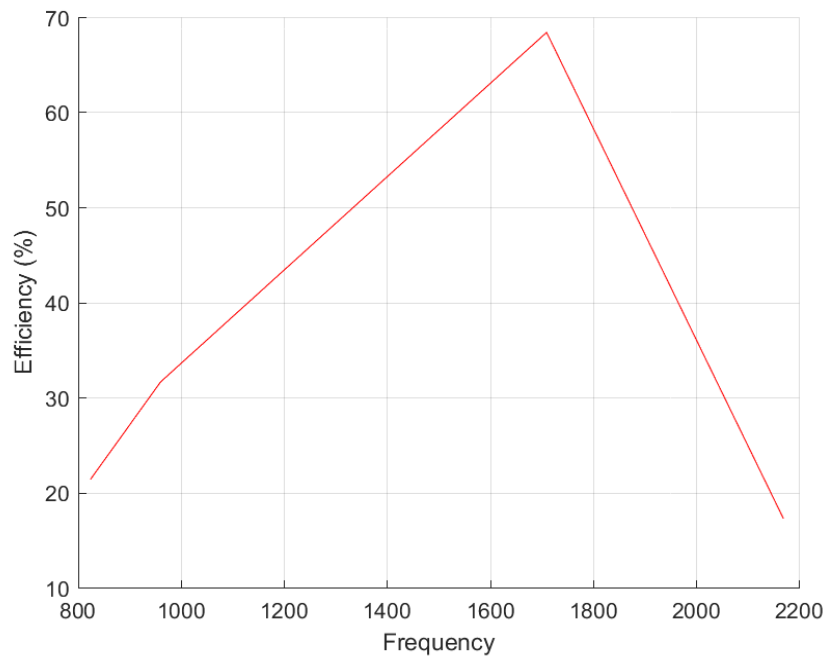

Total_Gain (dBi)

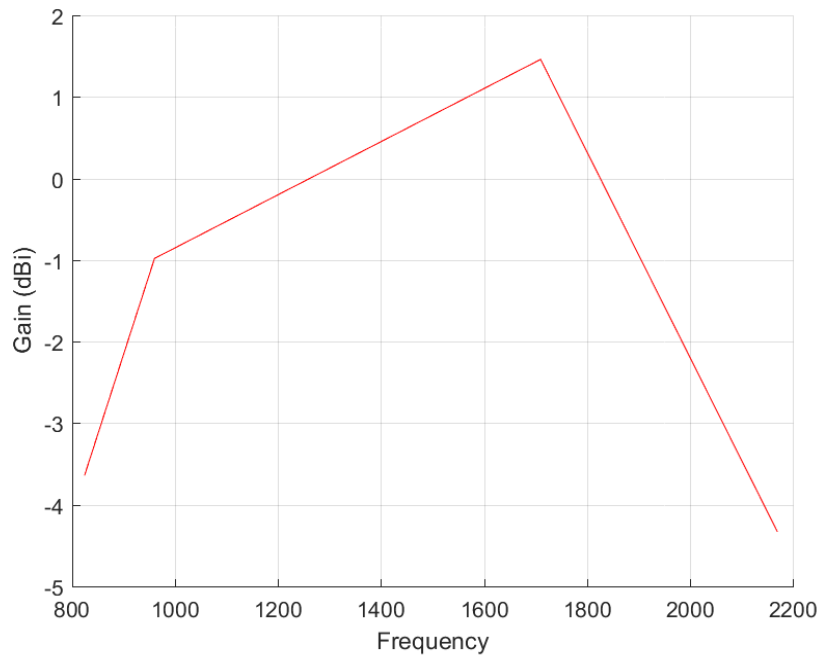

Total_3D_Top View_824MHz

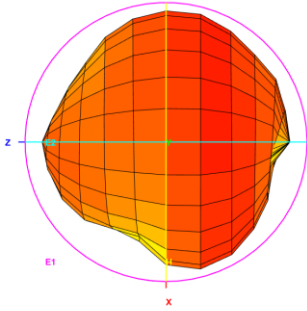

Total_3D_Front View_824MHz

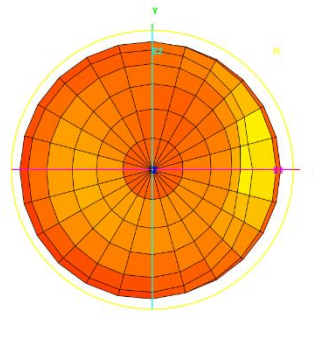

Total_3D_Left View_824MHz

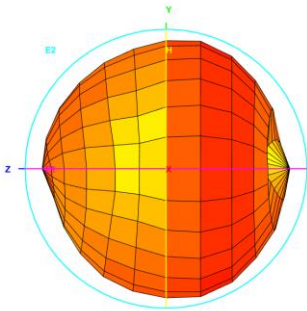

Total_3D_Side View 1_824MHz

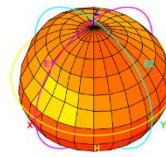

Total_3D_Top View_960MHz

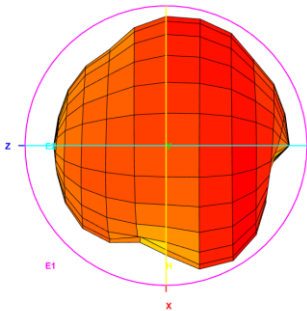

Total_3D_Front View_960MHz

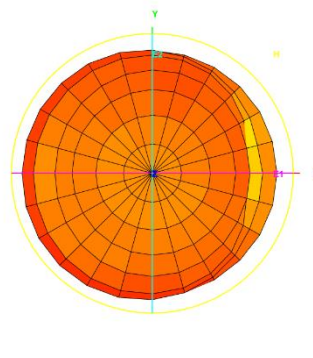

Total_3D_Left View_960MHz

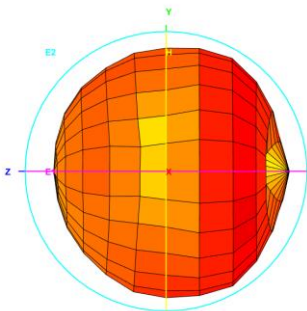

Total_3D_Side View 1_960MHz

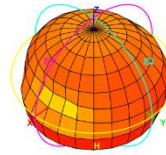

Total_3D_Top View_1.71GHz

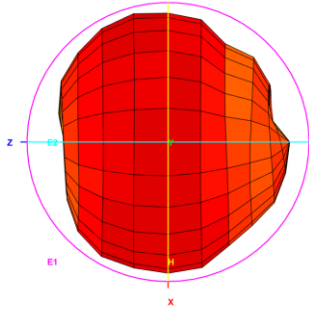

Total_3D_Front View_1.71GHz

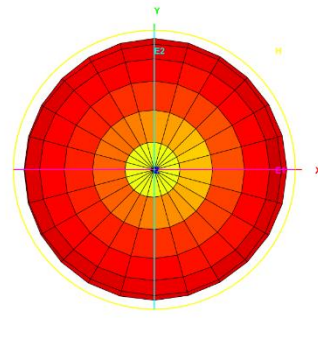

Total_3D_Left View_1.71GHz

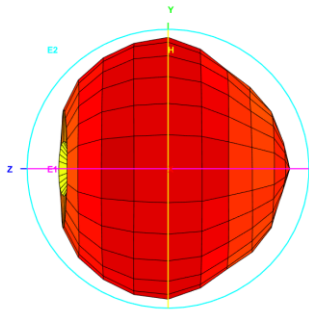

Total_3D_Side View 1_1.71GHz

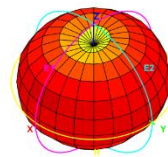

Total_3D_Top View_2.17GHz

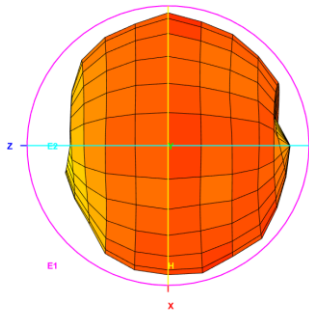

Total_3D_Front View_2.17GHz

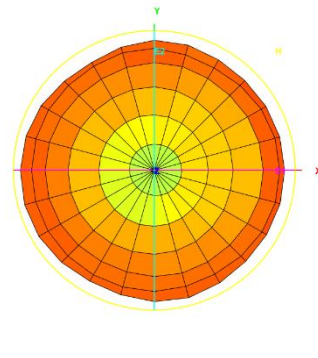

Total_3D_Left View_2.17GHz

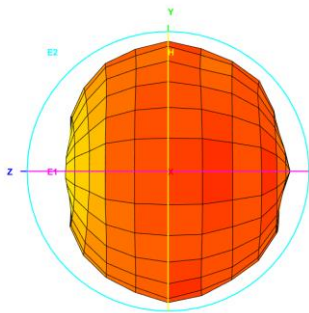

Total_3D_Side View 1_2.17GHz

