



CHINMORE INDUSTRY CO.,LTD

Specification

1. Adhesive Type Antenna for 2.4G (C09-5 Series)
2. Product's Name:
C09-5 Series with cable RG174 1M and connector SMA M F PIN
3. Frequency: 2.4GHz
4. VSWR: 2.0:1
5. Impedence: 50 Ω
6. Connector: SMA M F PIN
7. Cable: RG-174 1M
8. Dimension: 104*19mm
9. Color: Black

✘RoHS Compliant

✘ISO 9001 & ISO 14001

Cable	RG174/U
OD	ø2.7±0.15mm
Cover	Black (黑)
RP SMA M	Gold (鍍金)

Frequency	2.4GHz
V.S.W.R	2.0:1
Impedence	50Ω
Gain	2.5 dB
3M Sticker	4212(1.2mm)

綁線方式：8字型

ROHS

ISO 9001
ISO 14001

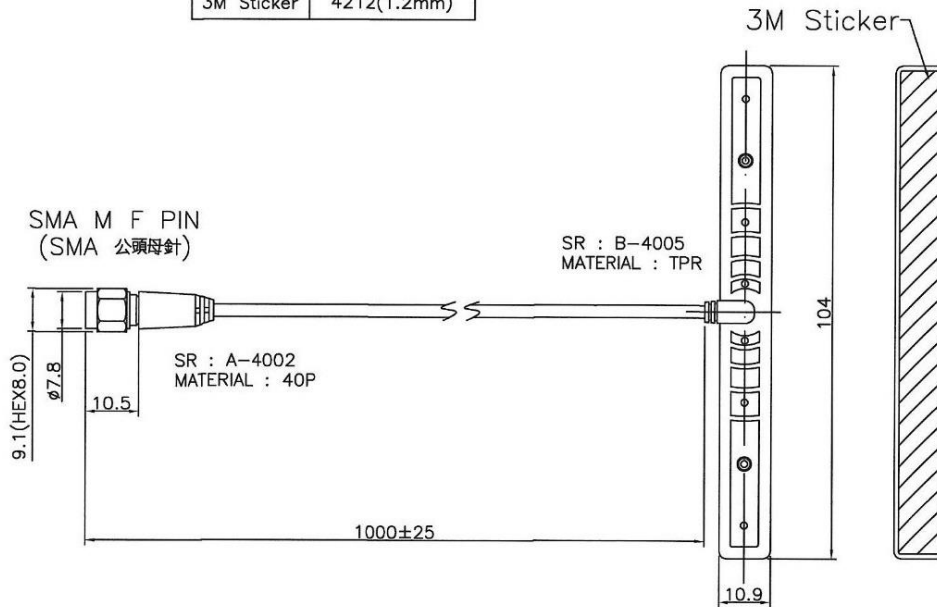

Material:	Treatment:	竣茂工業有限公司 Chinmore Industry CO.,LTD			
Drawer	Design	Aprov	Tolerance	Unit: mm	TITLE
			X=±0.5	mm	C09-5+174U+RP SMA M
			.X=±0.2	Ver: A	Scale 1:1
			.XX=±0.1	File NO: QR0402	Model NO
			.XXX=±0.05	Drawing NO	100-23005-0285

NO	DESCRIPTION	MATERIAL	FINISH	Q'TY
Part NO				

Frequency (MHz)	Return Loss (dB)	VSWR	Efficiency (%)	GAIN (dB)
2400	-15.89	1.38	72.95	6.38
2450	-19.19	1.27	63.1	6.49
2500	-15.17	1.44	59.84	6.55

Test Data(Return Loss & VSWR)

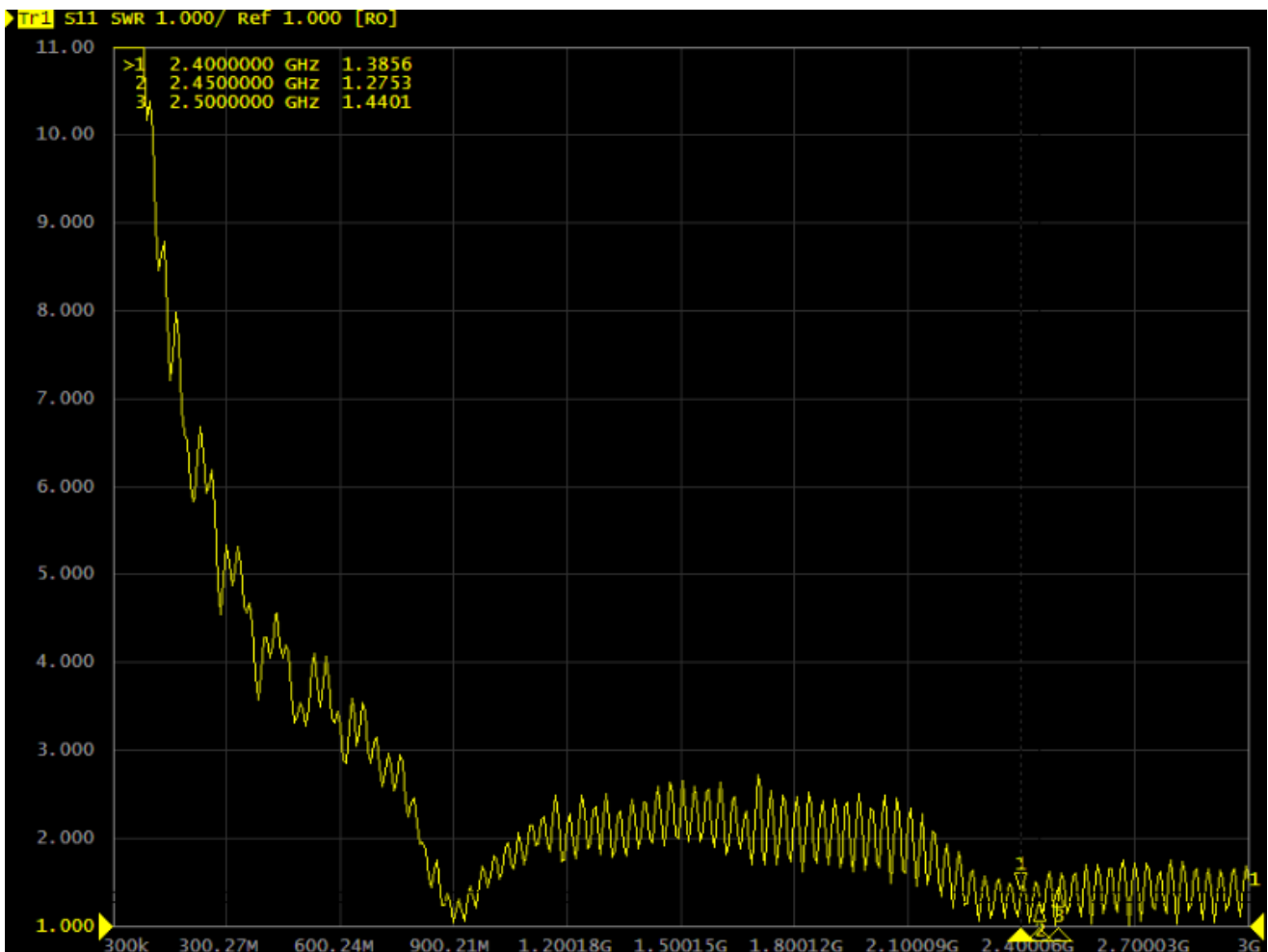
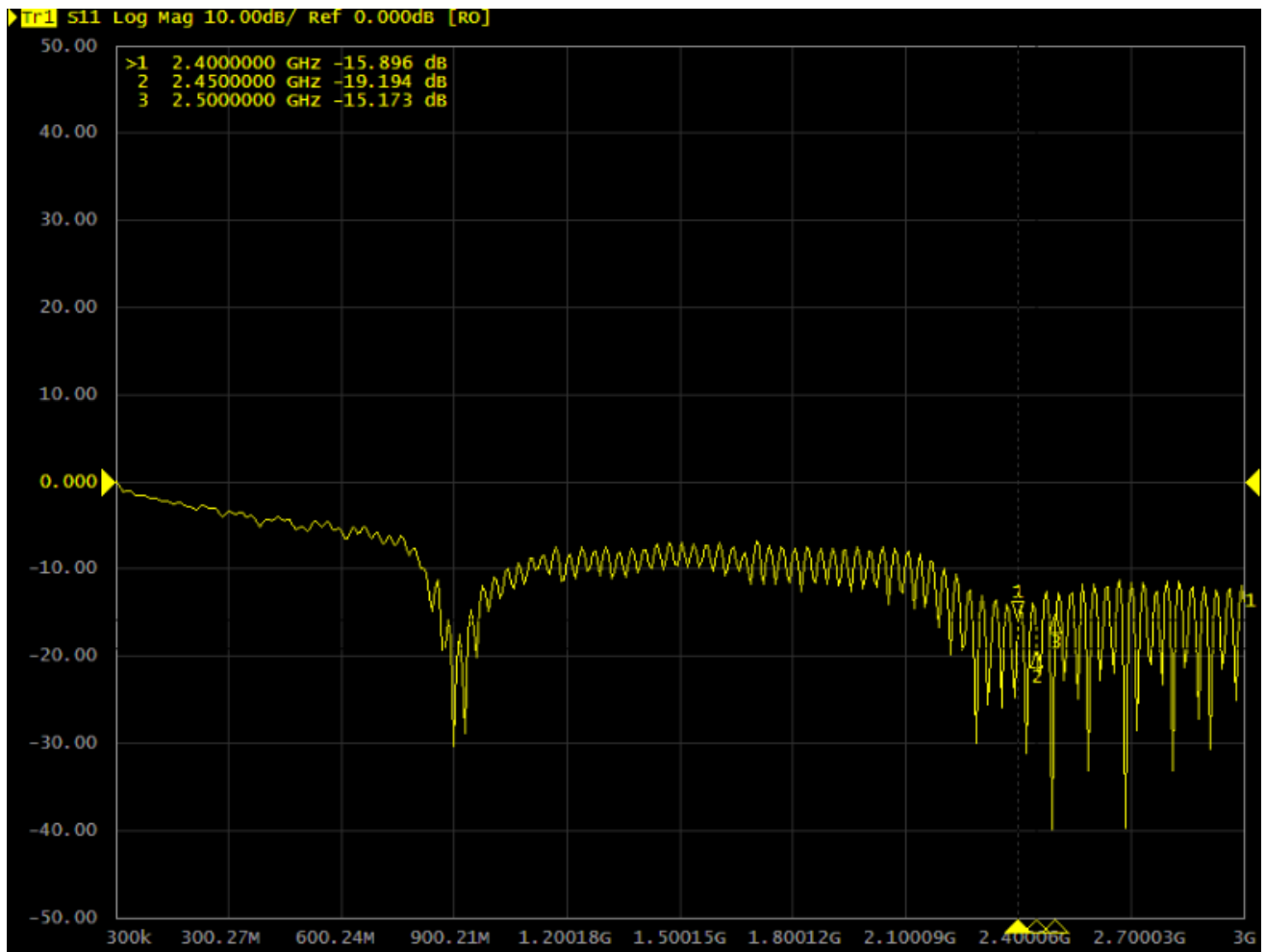

3D Test Photo

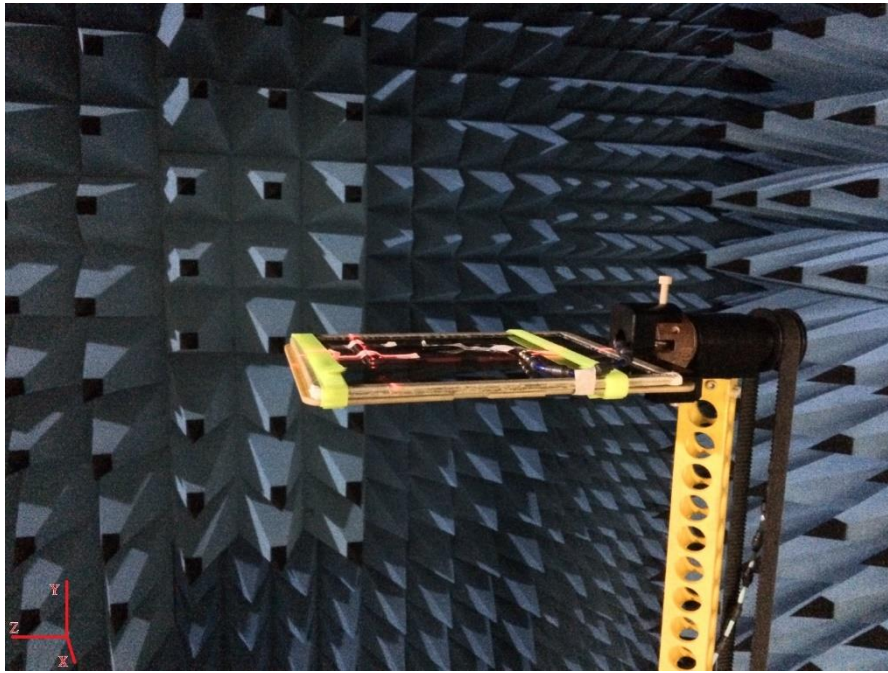

3D Test Data

Freq. / Chan.	Color
2.4GHz	Red
2.45GHz	Blue
2.5GHz	Green

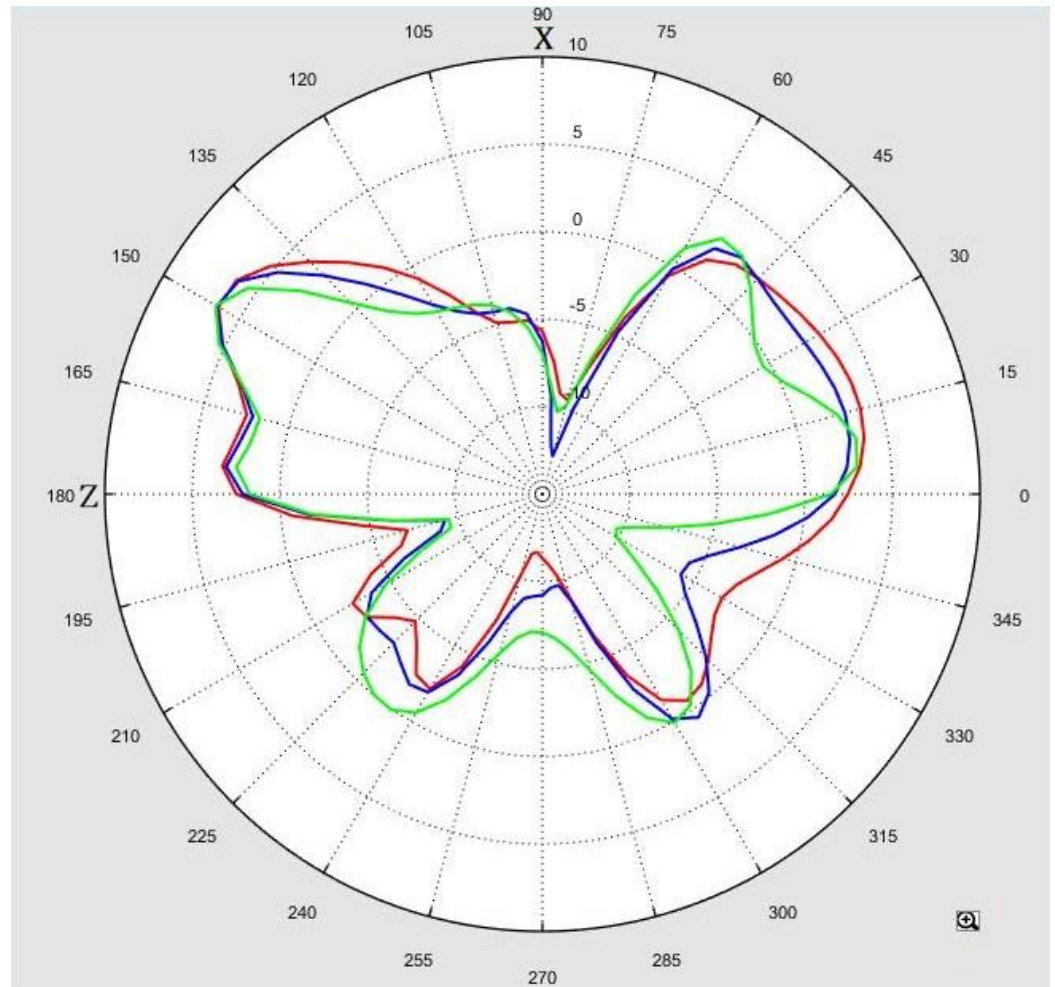

Total_Efficiency (%)

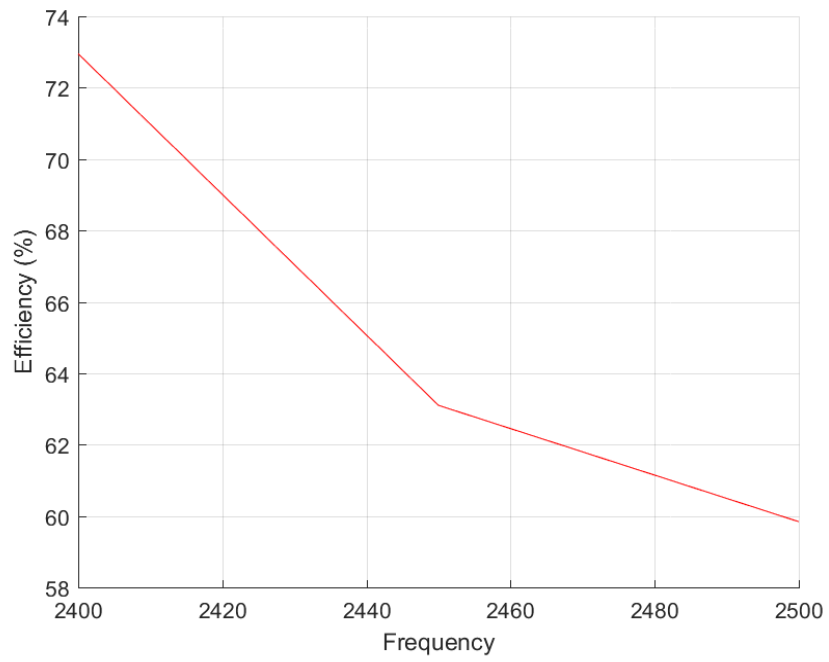

Total_Gain (dBi)

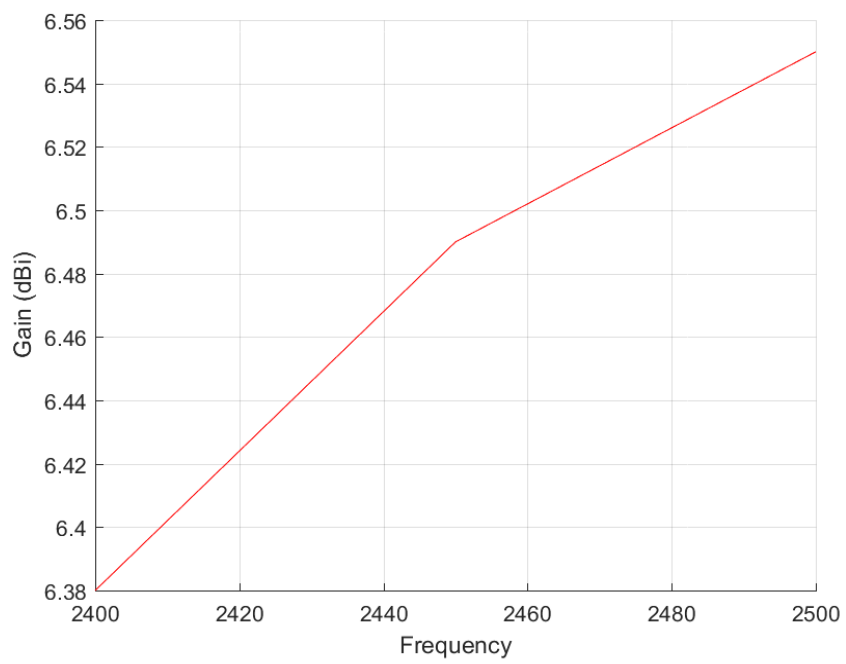

Total_3D_Top View_2.4GHz

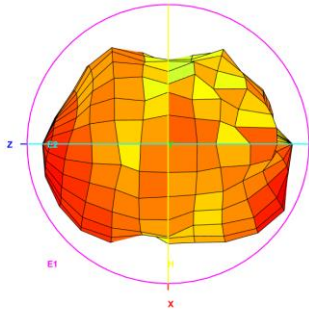

Total_3D_Front View_2.4GHz

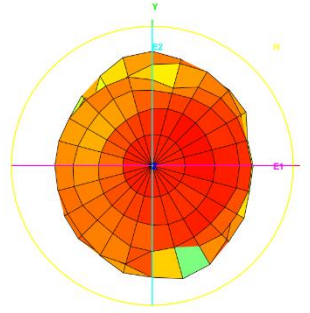

Total_3D_Left View_2.4GHz

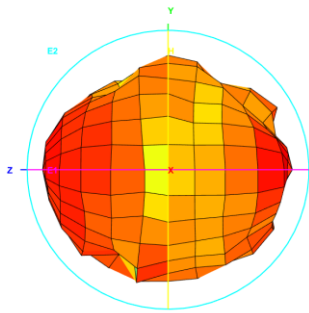

Total_3D_Side View 1_2.4GHz

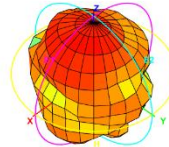

Total_3D_Top View_2.45GHz

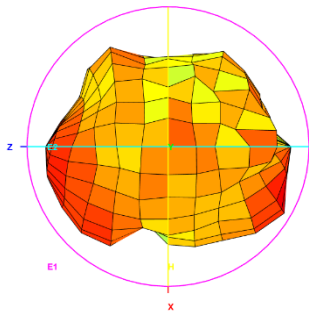

Total_3D_Front View_2.45GHz

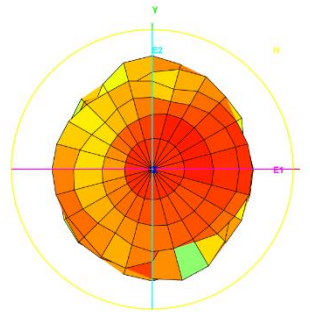

Total_3D_Left View_2.45GHz

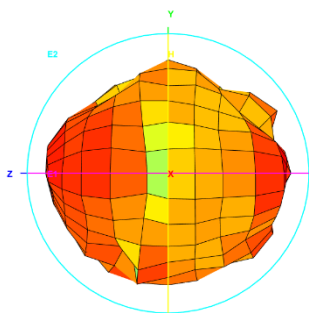

Total_3D_Side View 1_2.45GHz

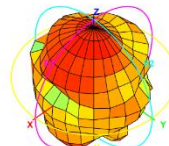

Total_3D_Top View_2.5GHz

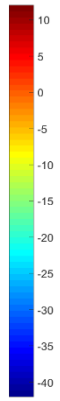
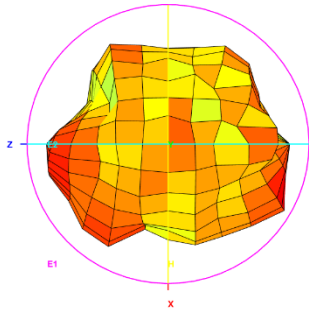

Total_3D_Front View_2.5GHz

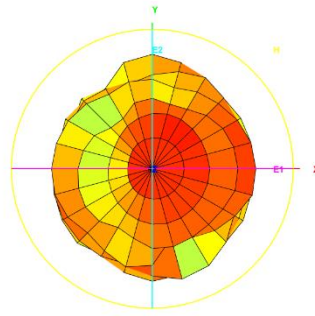

Total_3D_Left View_2.5GHz

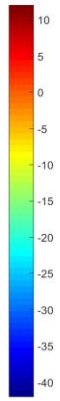
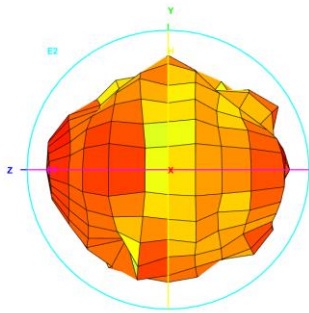

Total_3D_Side View 1_2.5GHz

