



CHINMORE INDUSTRY CO.,LTD

Specification

1. Cable Assembly with RF Connector
2. *Chinmore's* No: CX-MMCX174FME-242
3. Frequency: 1~3GHz
4. VSWR: 2.0:1
5. Cable: RG-174 100mm
6. Connector: FME M(BH) & RA MMCX M

✧RoHS Compliant

✧ISO 9001 & ISO 14001

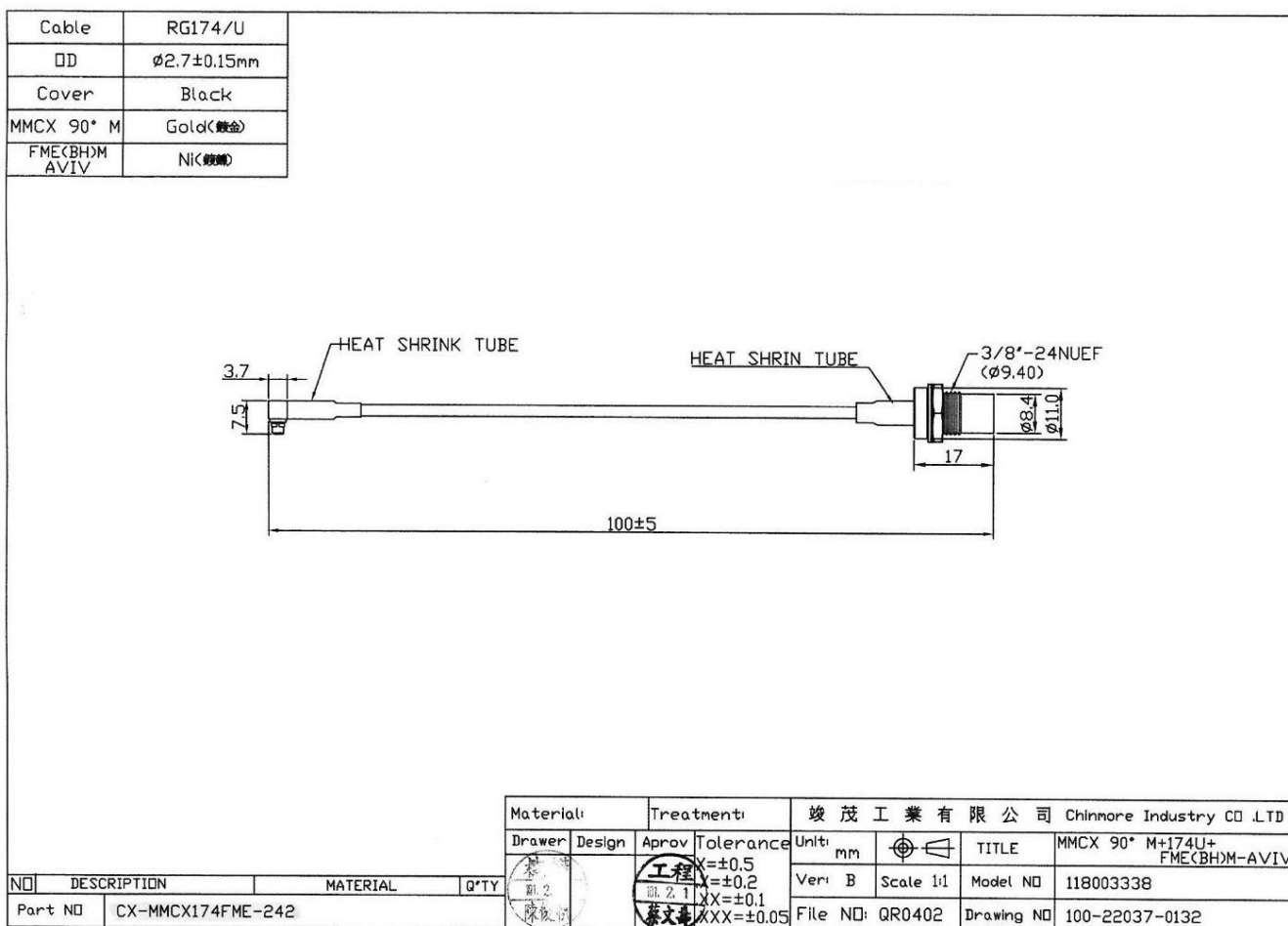

Frequency (MHz)	VSWR	Insertion Loss (dB)
1000	1.58	-0.50
2000	1.85	-0.94
3000	1.76	-1.11

TEST Report

