



CHINMORE INDUSTRY CO.,LTD

Specification

1. Combined Antenna for GPS and GSM (2-in-1) Antenna
2. *Chinmore's* No: GP-GPSGSMR32-102
3. Frequency for GPS: 1575.42 MHz
4. Frequency for GSM: 824/896/960/1710/1800/1880/1990/2170 MHz
5. VSWR: 2.5:1
6. Impedence: 50Ω
7. Cable: RG-174 3M
8. Connector: FAKRA C & FAKRA D

✧RoHS Compliant

✧ISO 9001 & ISO 14001

	Cable	OD	Cover	Connector	Frequency	Impedance	V.S.W.R
GPS				FAKRA C(Blue 藍色)	1575.42MHz	50Ω	2.5:1
GSM	RG174/U	ø2.7±0.15	Black (黑)	FAKRA D(Purple 紫色)	824~896~960MHz 1710~1800~1880MHz 1990~2170MHz		

ISO 9001
ISO 14001

Technical drawing details:
 - Antenna diameter: 38.4
 - Antenna length: 22.25, 19.25
 - Cable length: 3000±50
 - Connector D (POM) length: 22
 - Connector C (POM) length: 26.25
 - Material: SR : B-3003 MATERIAL : ABS; SR : MS-B3008 Material : TPR
 - Dimensions for connector mounting: 9.25, 7.3, 1.3, 1.2, 90°, 1.3, 1.2

Material:	Treatment:	竣茂工業有限公司 Chinmore Industry CO.,LTD	
Drawer	Design	Approval	Tolerance
		機務	X=±0.5
		前. 3. 16	X=±0.2
		檢驗	XX=±0.1
			.XXX=±0.05
Unit:	mm	Ver:	A
Scale:	1:1	Model NO:	WIREAC1120
File NO:	QR0402	Drawing NO:	100-23005-055

Frequency (MHz)	Return Loss (dB)	VSWR	Efficiency (%)	Gain (dBi)
1575.42 (GPS)	-15.63	1.39	-----	32.59
824	-7.74	2.39	26.42	0.83
896	-11.13	1.78	28.05	1.7
960	-12.40	1.63	17.7	-0.66
1710	-21.16	1.19	49.66	0.47
1800	-19.08	1.25	48.31	0.55
1880	-13.48	1.56	32.89	-0.15
1990	-17.26	1.40	12.85	-3.98
2170	-17.06	1.35	9.48	-4.47

Patch

Characteristics	Specification
Center Frequency	1575.42±1.023 MHz (when covered with a radome and measured by LNA ground plane)
Bandwidth (10dB return loss)	10 MHz min
Gain at Zenith	0.5 dBic typ
Gain at 10° elevation	- 6 dBic typ
Polarization	R.H.C.P
Axial Ratio	1.0 dB typ

Filter / LNA

Characteristics	Specification
Center Frequency	1575.42 ±1.023 MHz
Gain	30~37dB (ps:3v / 32dB)
Noise Figure	1.5 dB typ (ps: 3v / 1.5dB)
Filter (Out of band attenuation)	Dielectric filter 7dB min fo±20MHz 20dB min fo±50MHz 30dB min fo±100MHz (fo=1575.42MHz)
Output V.S.W.R	2.0 max
Voltage	DC = 2.5~5.5V
Current	DC = 8~23mA (ps: 3v / 10mA)

Test Report(Return Loss & VSWR)

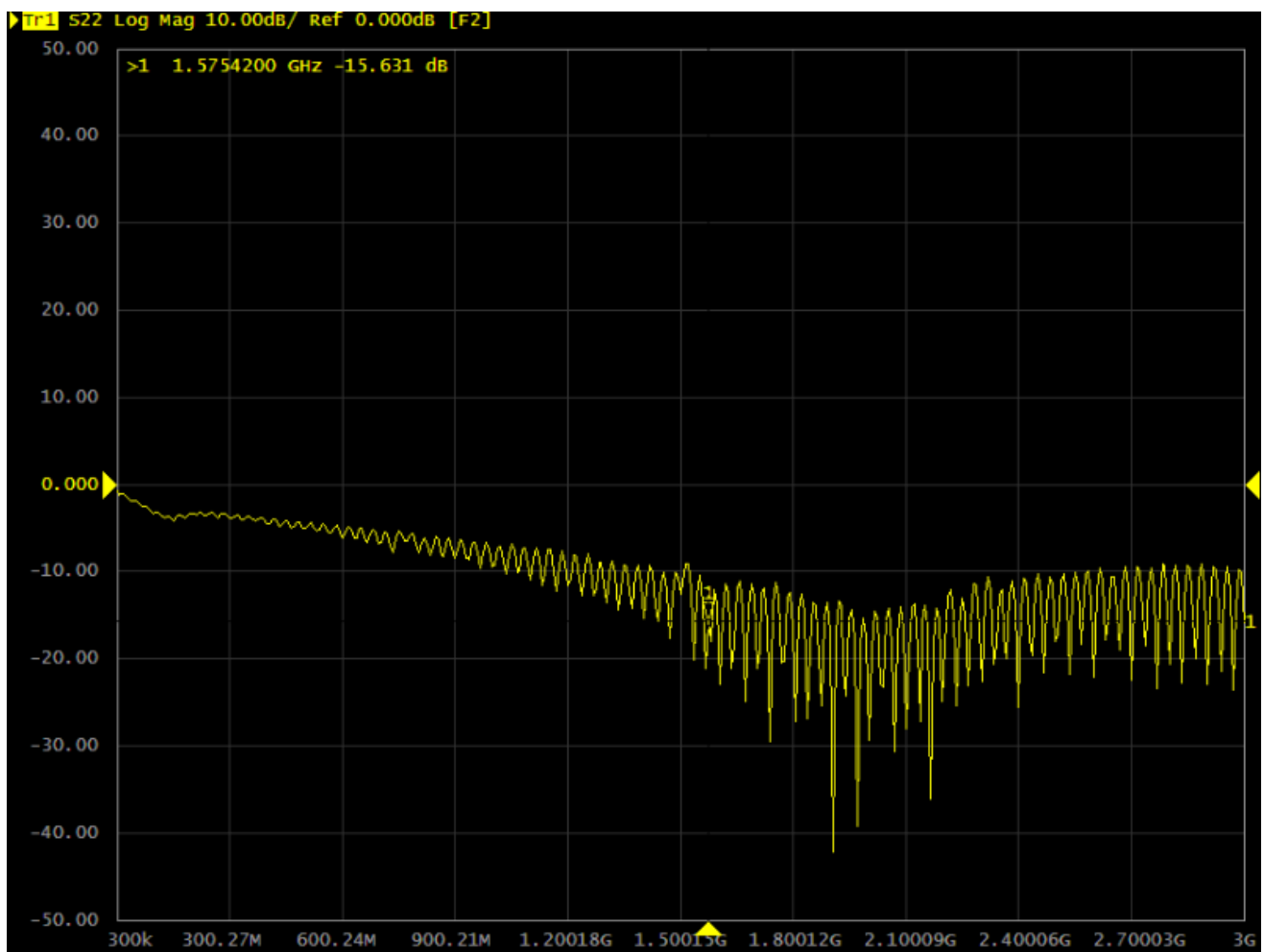



3D Test Photo

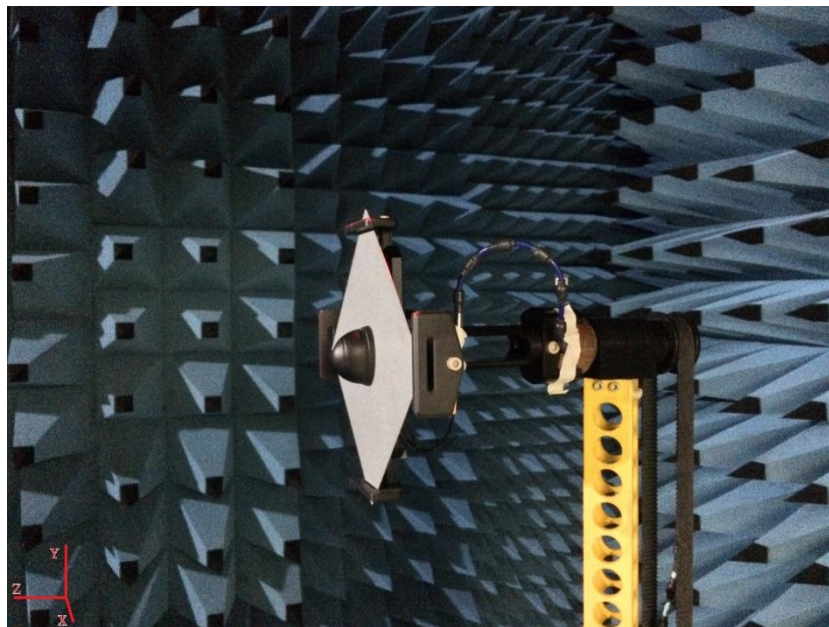

3D Test Data

Freq. / Chan.	Color
1.57542GHz	█

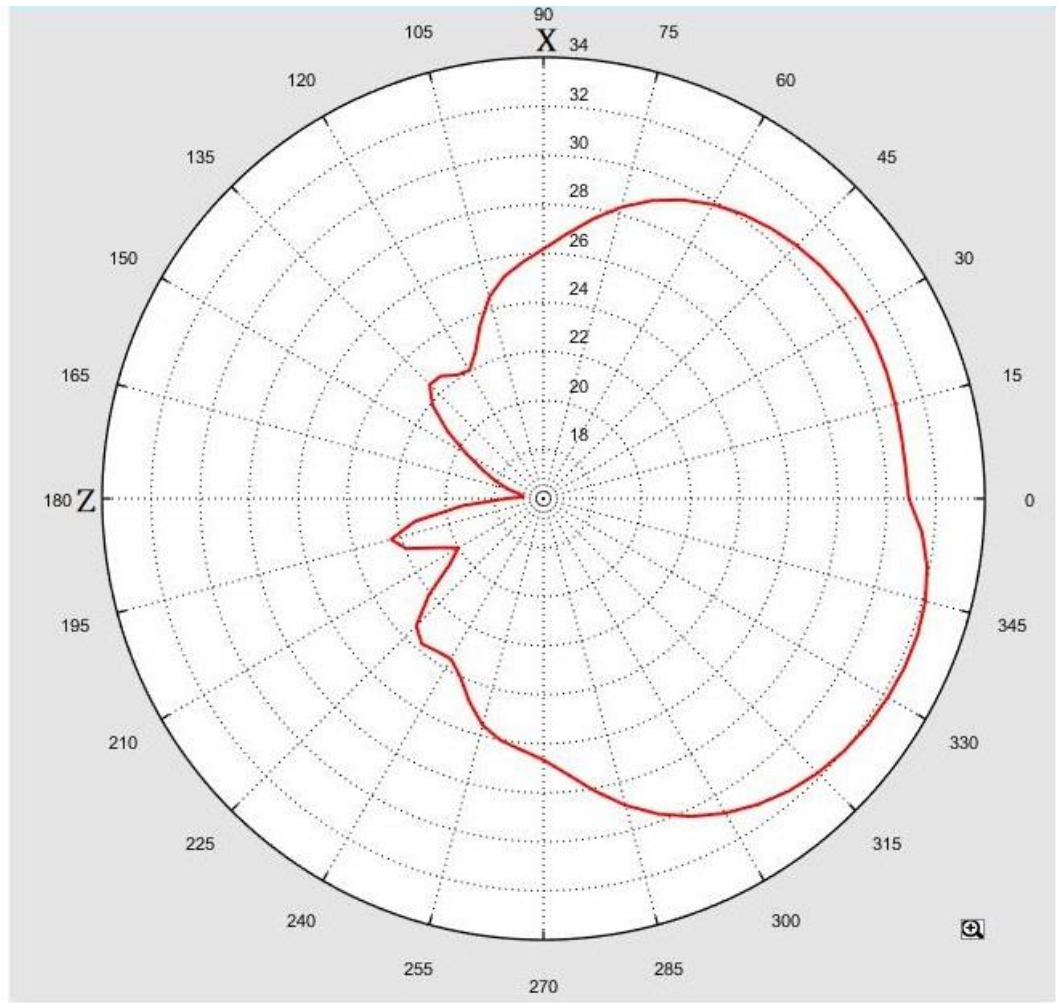

Total_3D_Top View_1.57542GHz

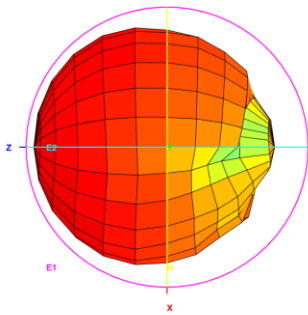

Total_3D_Front View_1.57542GHz

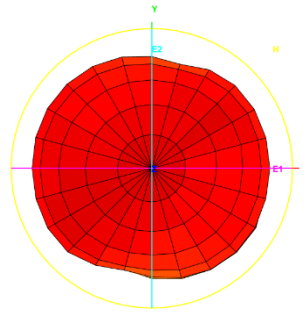

Total_3D_Left View_1.57542GHz

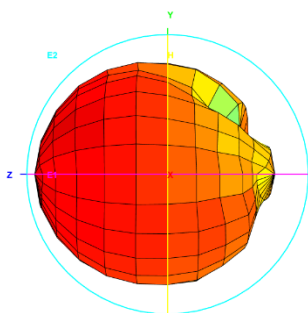

Total_3D_Side View_1.57542GHz

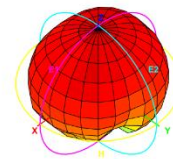

Test Report(Return Loss & VSWR)(3G)

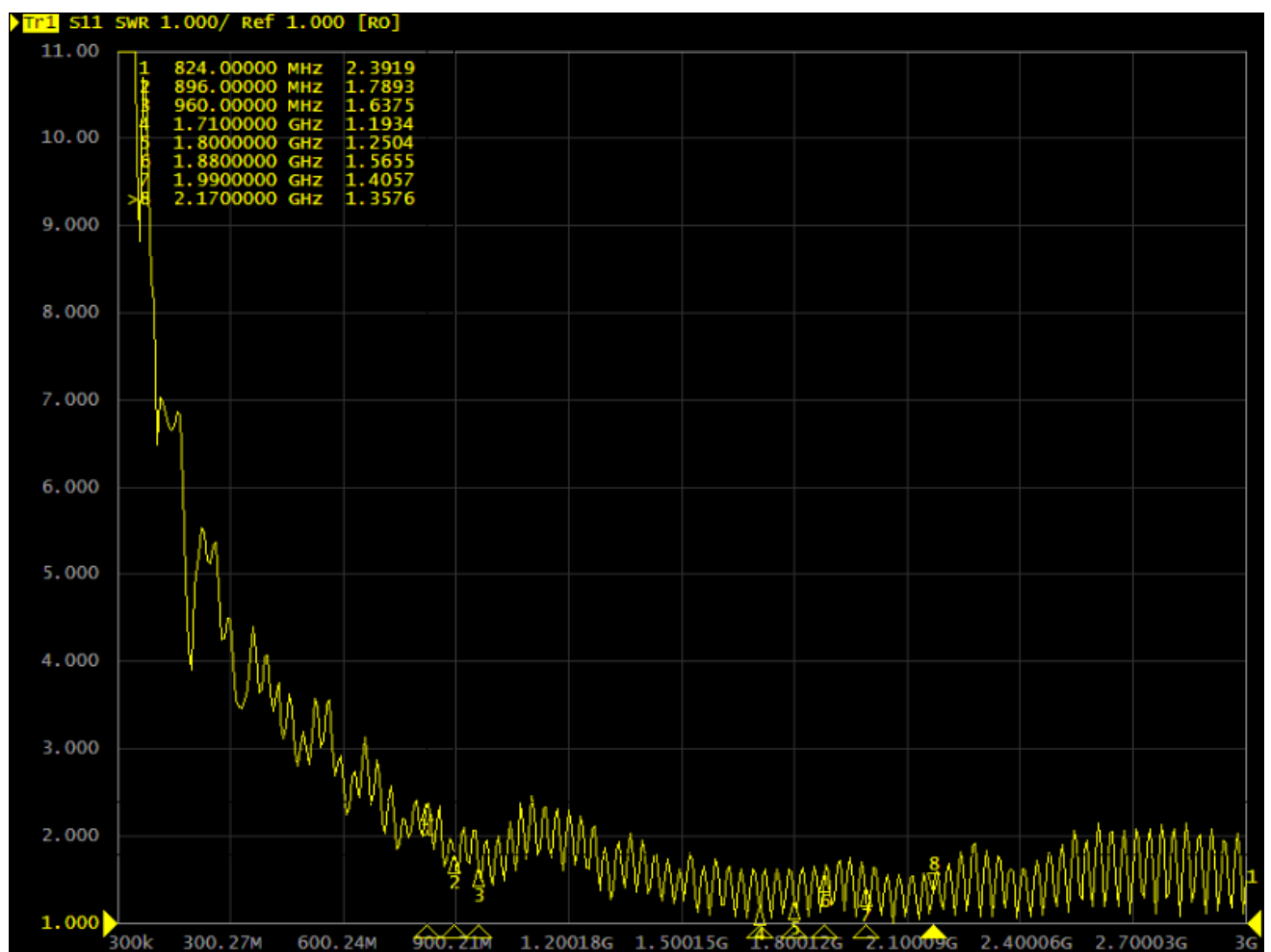
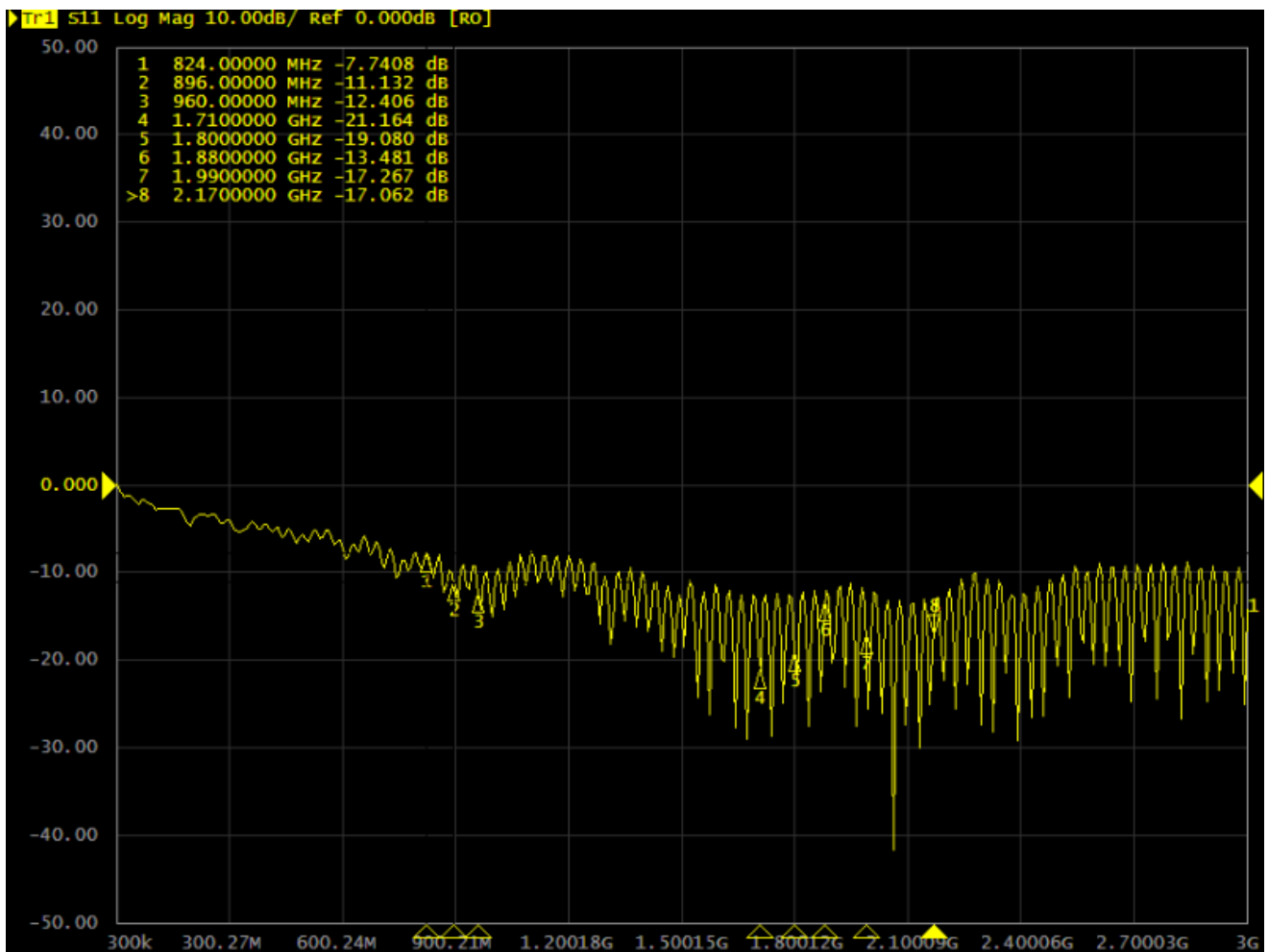

3D Test Data

Freq. / Chan.	Color
824MHz	Red
896MHz	Blue
960MHz	Green
1.71GHz	Magenta
1.8GHz	Cyan
1.88GHz	Yellow
1.99GHz	Black
2.17GHz	Purple

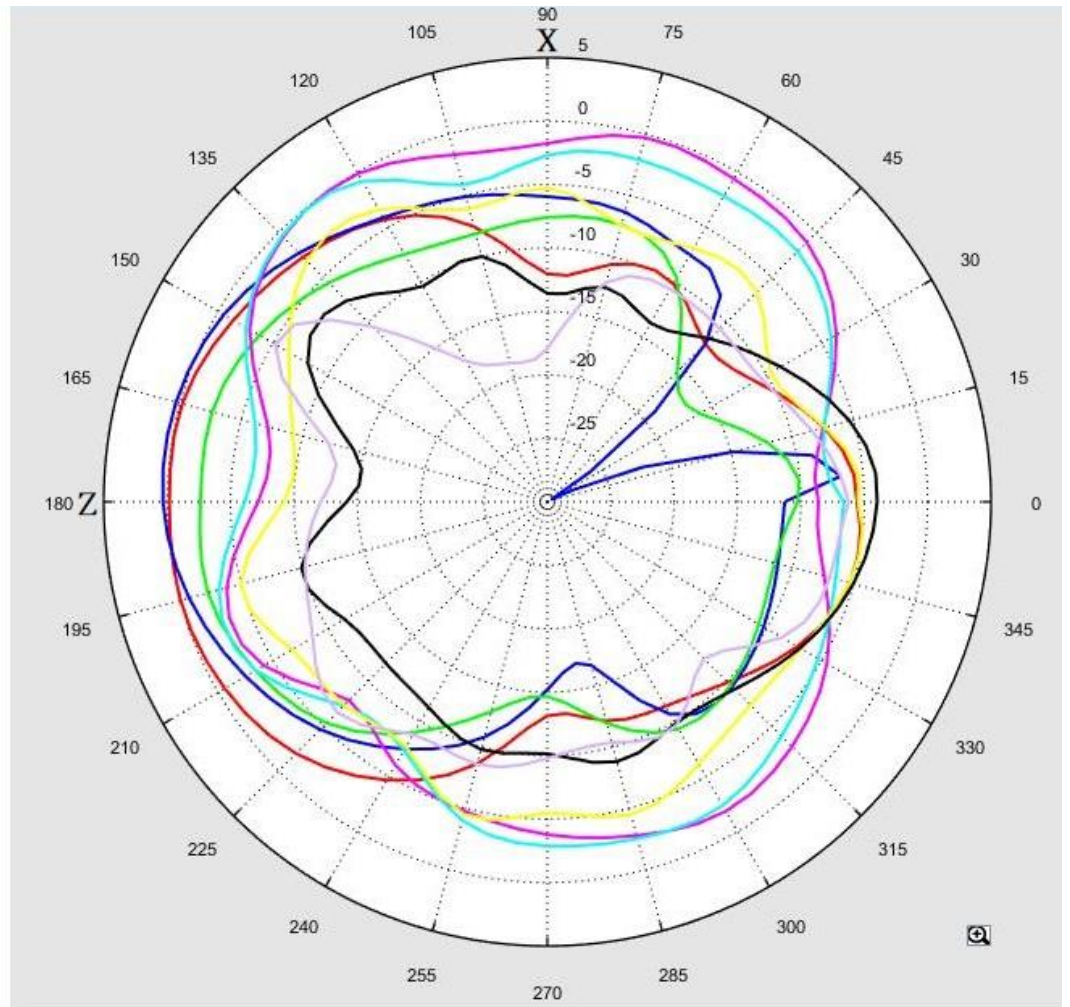

Total_Efficiency (%)

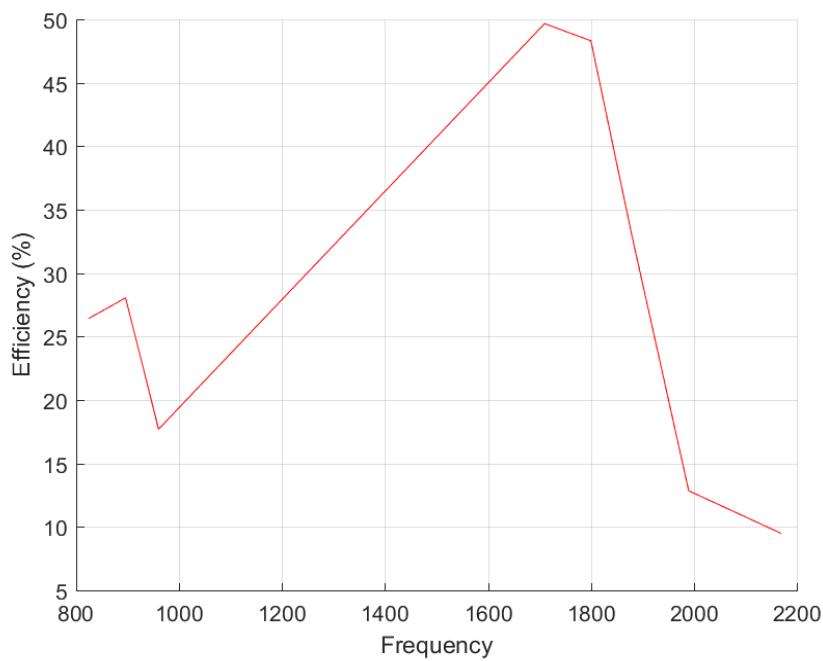

Total_Gain (dBi)

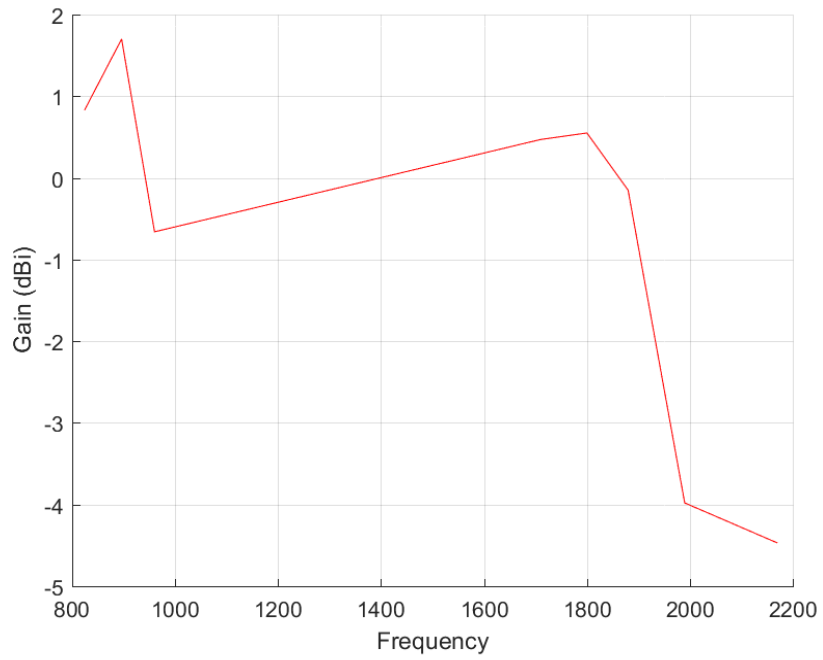

Total_3D_Top View_824MHz

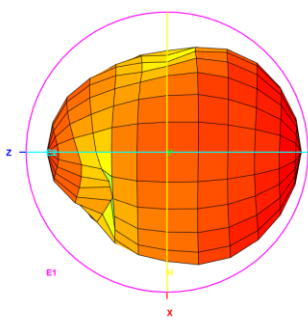

Total_3D_Front View_824MHz

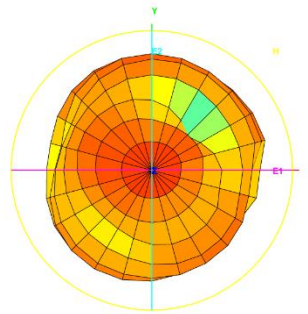

Total_3D_Left View_824MHz

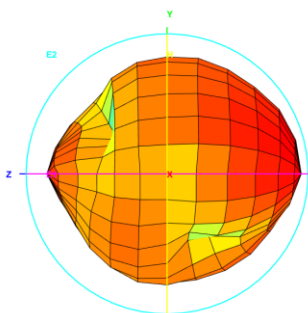

Total_3D_Side View 1_824MHz

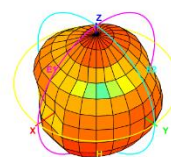

Total_3D_Top View_896MHz

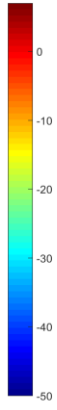
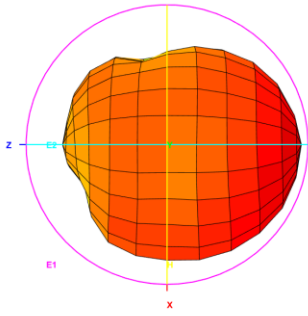

Total_3D_Front View_896MHz

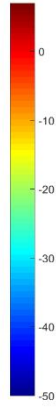
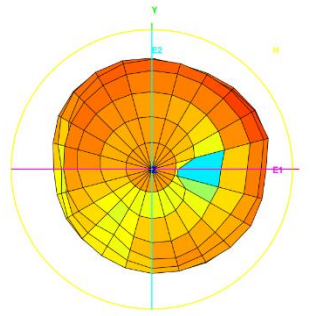

Total_3D_Left View_896MHz

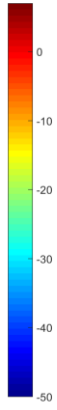
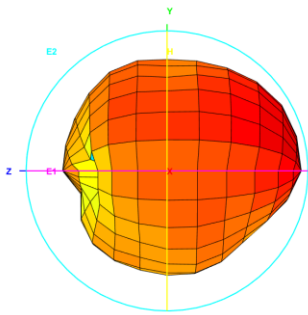

Total_3D_Side View 1_896MHz

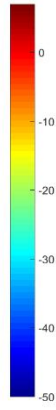
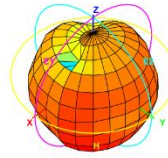

Total_3D_Top View_960MHz

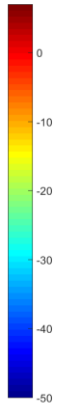
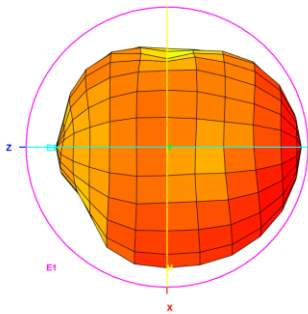

Total_3D_Front View_960MHz

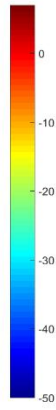
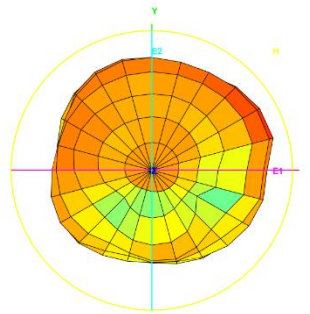

Total_3D_Left View_960MHz

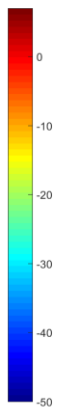
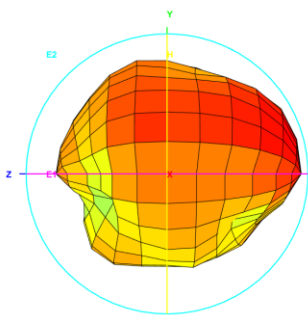

Total_3D_Side View 1_960MHz

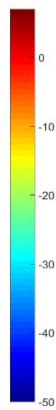
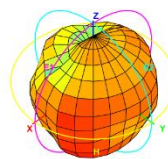

Total_3D_Top View_1.71GHz

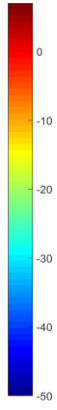
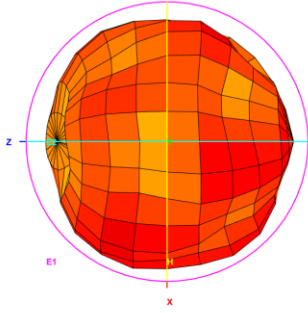

Total_3D_Front View_1.71GHz

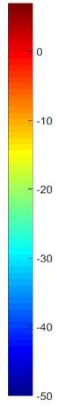
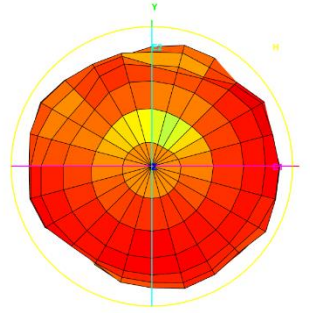

Total_3D_Left View_1.71GHz

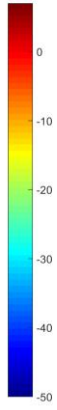
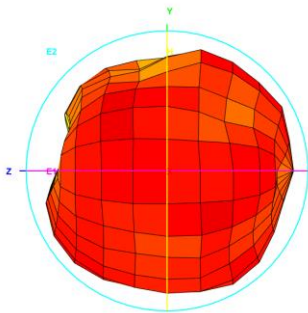

Total_3D_Side View_1.71GHz

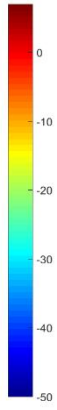
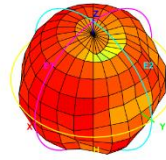

Total_3D_Top View_1.8GHz

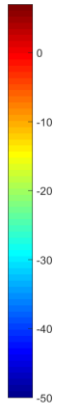
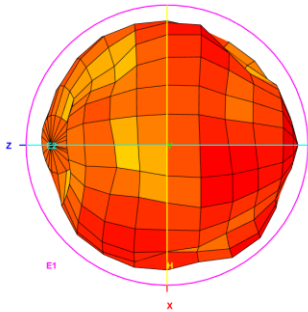

Total_3D_Front View_1.8GHz

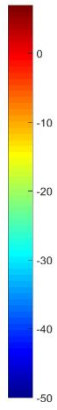
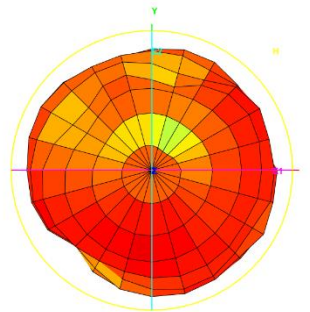

Total_3D_Left View_1.8GHz

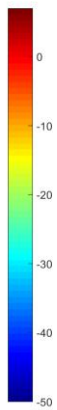
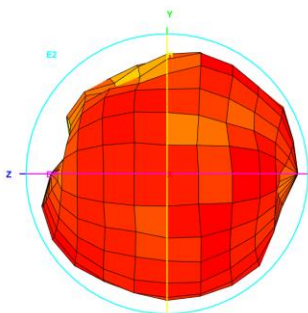

Total_3D_Side View_1.8GHz

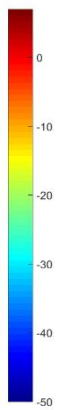
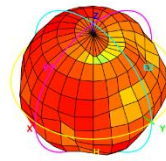

Total_3D_Top View_1.88GHz

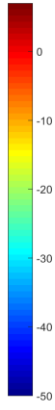
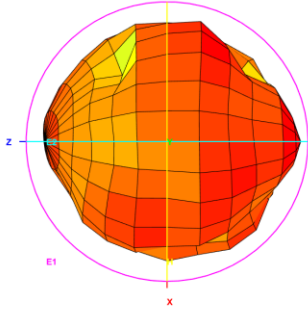

Total_3D_Front View_1.88GHz

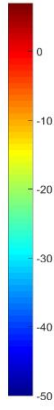
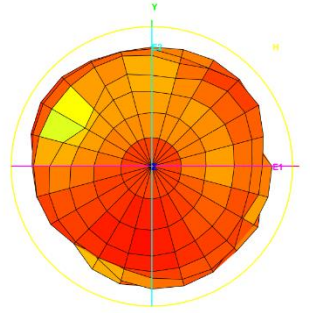

Total_3D_Left View_1.88GHz

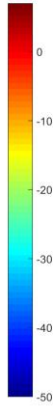
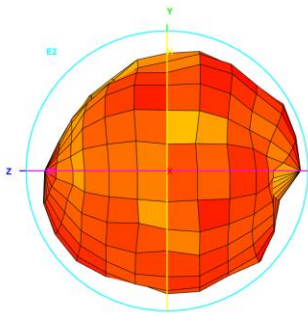

Total_3D_Side View_1.88GHz

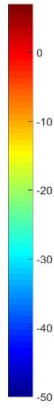
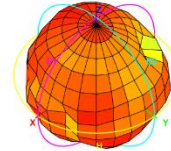

Total_3D_Top View_1.99GHz

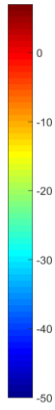
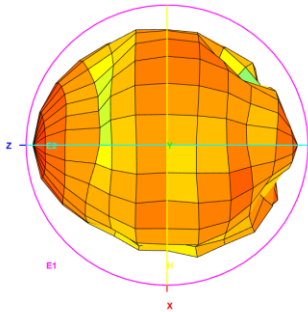

Total_3D_Front View_1.99GHz

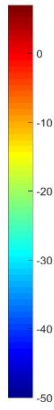
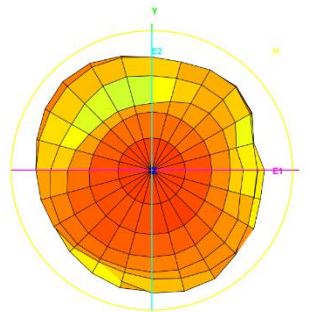

Total_3D_Left View_1.99GHz

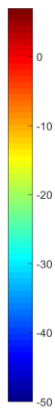
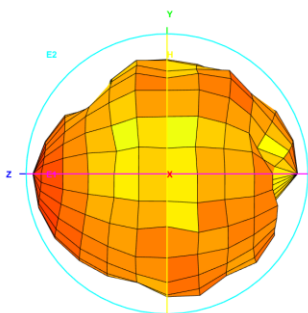

Total_3D_Side View_1.99GHz

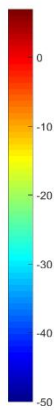
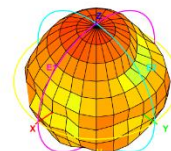

Total_3D_Top View_2.17GHz

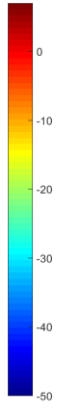
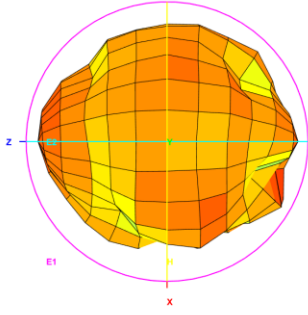

Total_3D_Front View_2.17GHz

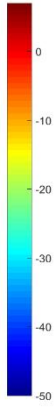
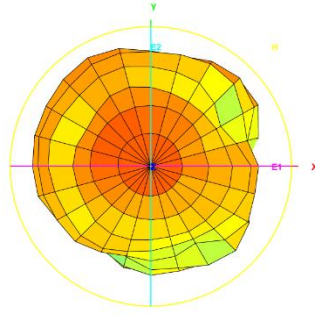

Total_3D_Left View_2.17GHz

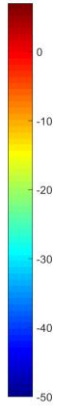
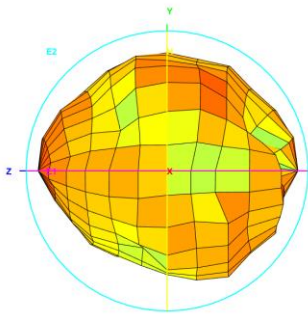

Total_3D_Side View 1_2.17GHz

