



CHINMORE INDUSTRY CO.,LTD

Specification

1. Adhesive Type Antenna for 4G/LTE (C09-1 series)
2. Chinmore's No: CA-C09-1MMCX-326
3. Frequency: 690~960/1770~2700 MHz
4. VSWR:2.0:1
5. Gain: 2.5 dBi
6. Connector: RA MMCX M
7. Cable: RG-174 300mm

※ISO 9001 & ISO 14001

※RoHS Compliant

Cable	RG174U	Frequency	690~960MHz	3M Sticker	1.2mm	<div style="border: 2px solid black; padding: 5px; display: inline-block;">ROHS</div> ISO 9001 ISO 14001
OD	ø2.7±0.15mm		1770~2700MHz		PK-L15.0X117B-023	
Cover	Black (黒)	4G/LTE	C09-1(800M)			
MMCX M 90	Gold (金)	V.S.W.R	2.0:1	P.C 板	PB-92800FR4-004	
		Impedence	50Ω			
		Gain	2.5 dB			

Material:		Treatment:		竣茂工業有限公司 Chinmore Industry CO .LTD			
Drawer	Design	Appro	Tolerance	Unit: mm		TITLE	C09-1+174U+MMCX M 90
2019/10/17 頻率改為4G		X=±0.5		Ver: A	Scale 1:1	Model NO	WIREAC1695
NOI	DESCRIPTION	MATERIAL / FINISH	Q'TY	X=±0.2		File NO:	QR0402
Part NO	CA-C09-1MMCX-326			XX=±0.1		Drawing NO	100-23005-247
				XXX=±0.05			

Frequency (MHz)	Return Loss (dB)	VSWR	Efficiency (%)	Gain (dB)
700	-5.16	3.52	44.57	1.06
750	-7.19	2.71	50.35	2.46
800	-15.72	1.48	56.23	2.8
850	-11.55	1.66	54.7	2.17
900	-7.41	2.46	68.08	2.01
1800	-10.39	1.92	76.21	4.08
1900	-24.51	1.21	70.31	4.6
2100	-9.16	1.80	34.59	2.53
2700	-7.96	2.33	52.84	4.66

Test Data(Return Loss & VSWR)

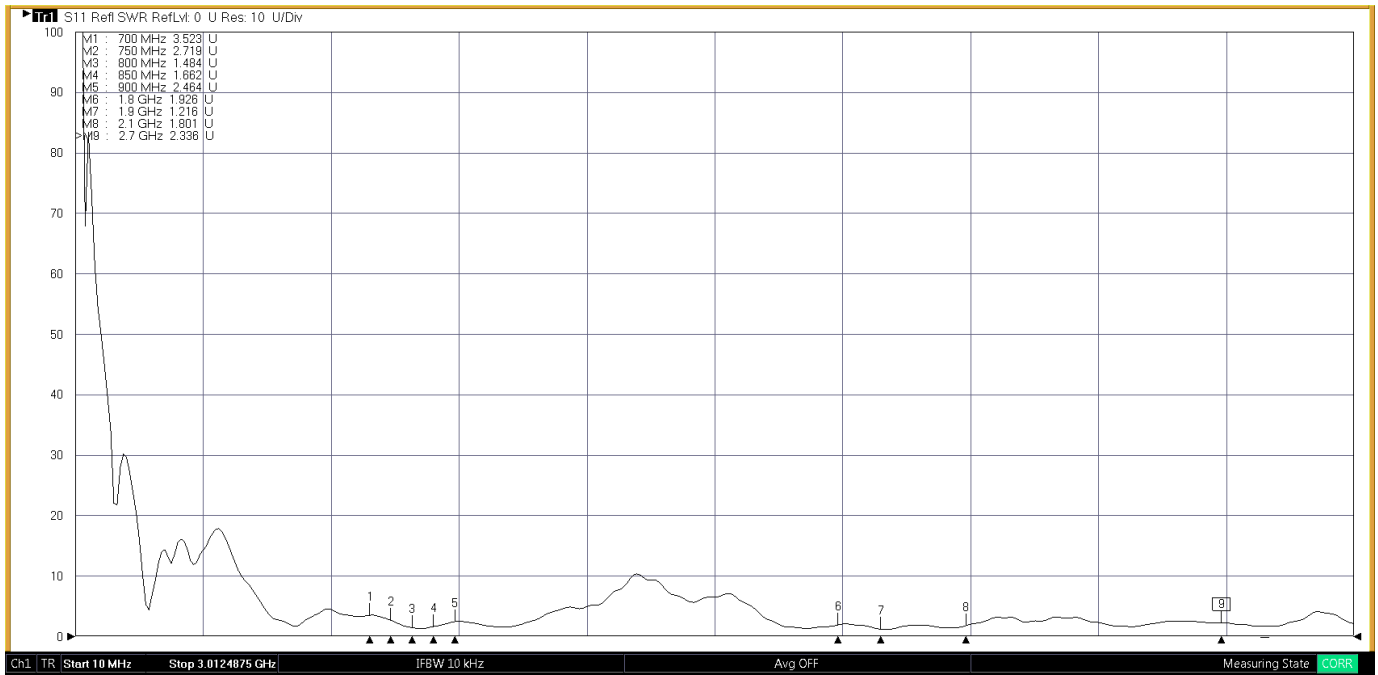

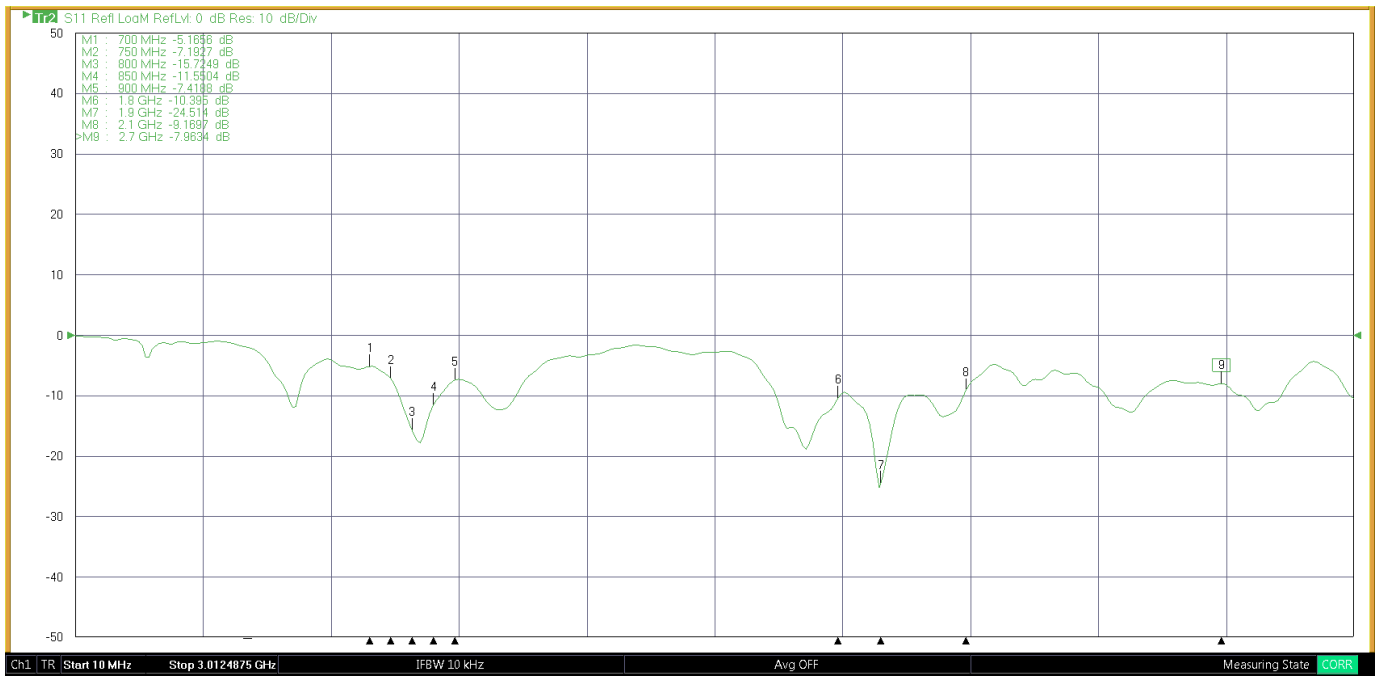

3D Test photo

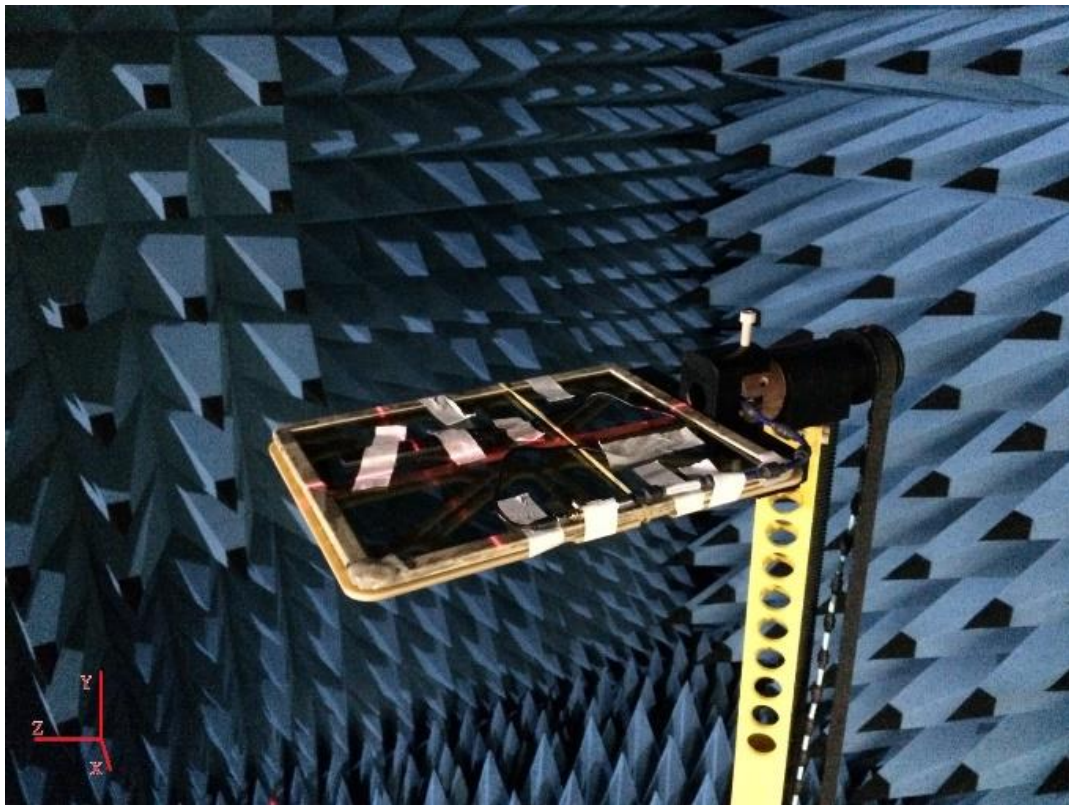

3D Test Report

Freq. / Chan.	Color
700MHz	Red
750MHz	Blue
800MHz	Green
850MHz	Magenta
900MHz	Cyan
1.8GHz	Yellow
1.9GHz	Black
2.1GHz	Light Purple
2.7GHz	Dark Blue

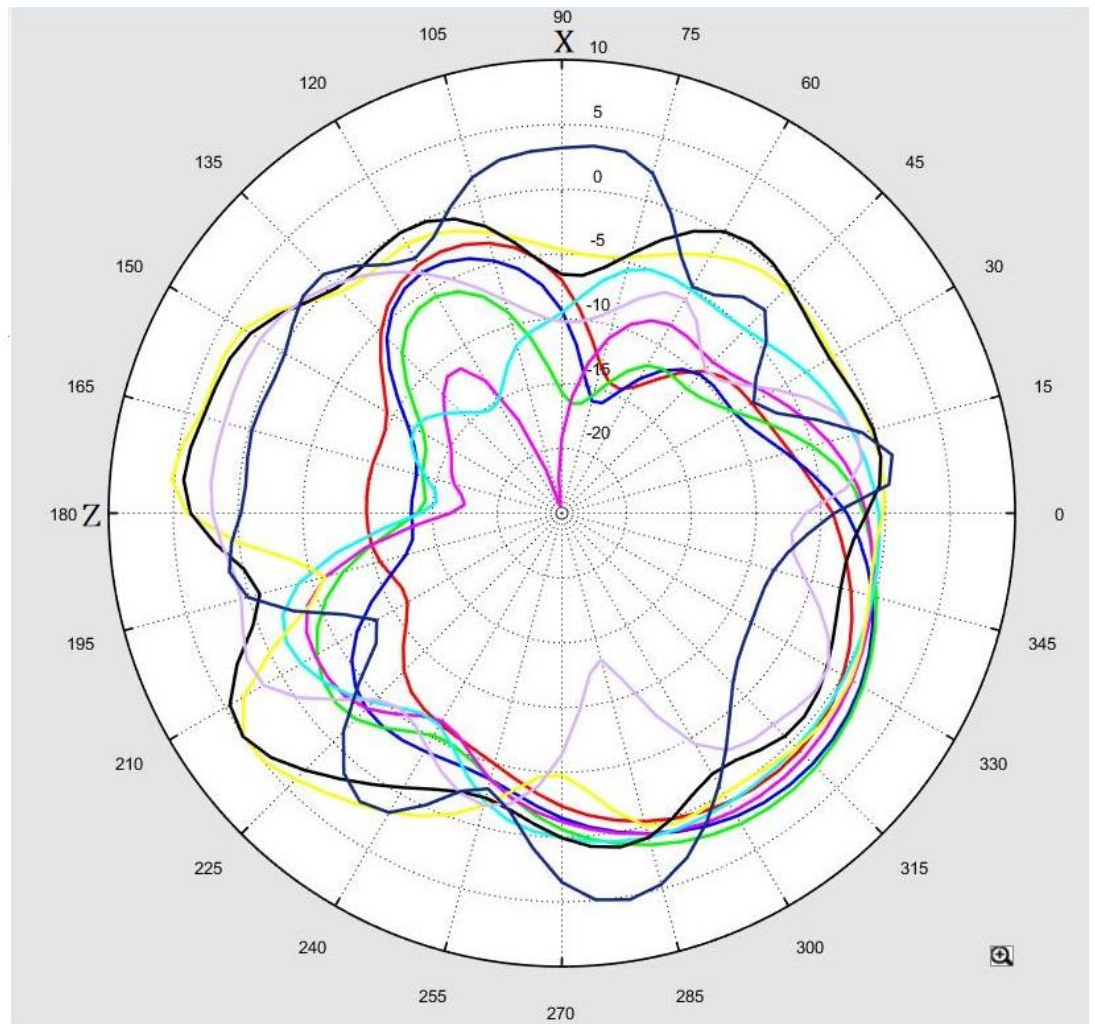

Total_Efficiency (%)



Total_Gain (dBi)



Total_3D_Top View_700MHz

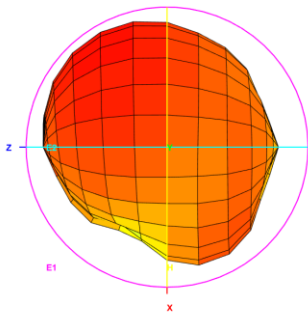

Total_3D_Front View_700MHz

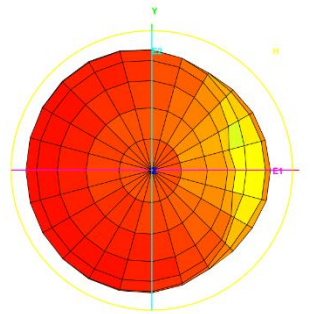

Total_3D_Left View_700MHz

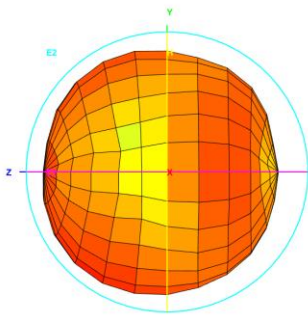

Total_3D_Side View 1_700MHz

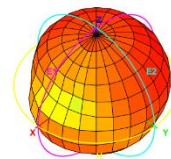

Total_3D_Top View_750MHz

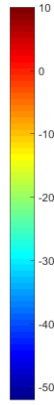
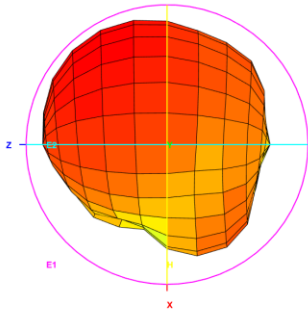

Total_3D_Front View_750MHz

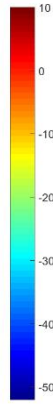
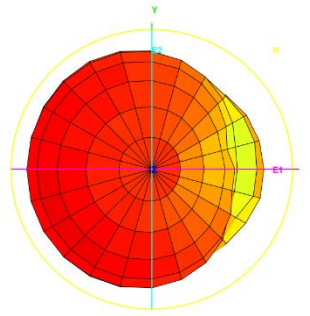

Total_3D_Left View_750MHz

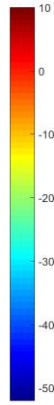
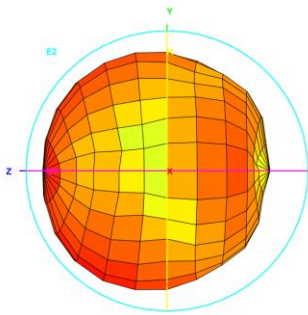

Total_3D_Side View 1_750MHz

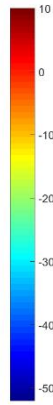
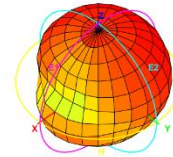

Total_3D_Top View_800MHz

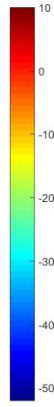
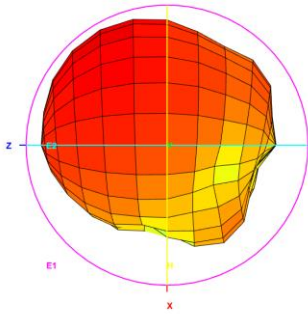

Total_3D_Front View_800MHz

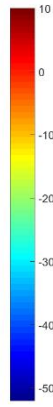
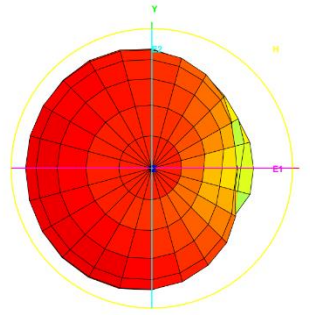

Total_3D_Left View_800MHz

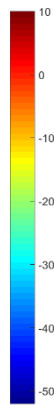
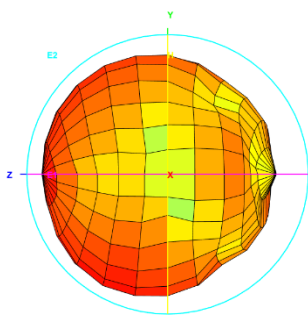

Total_3D_Side View 1_800MHz

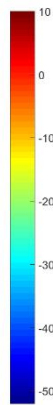
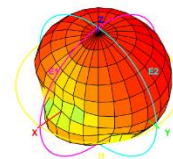

Total_3D_Top View_850MHz

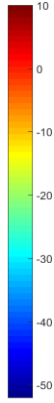
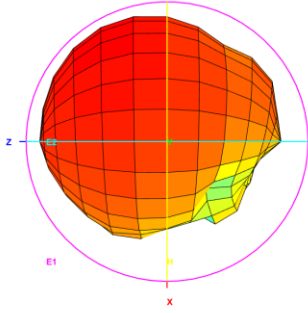

Total_3D_Front View_850MHz

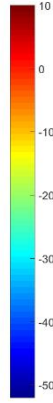
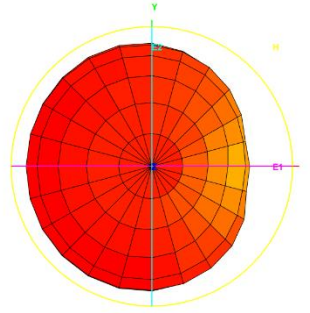

Total_3D_Left View_850MHz

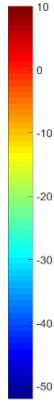
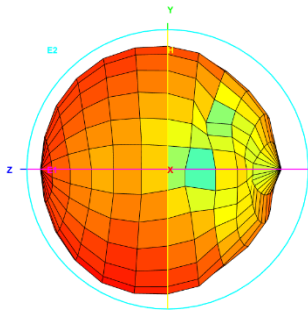

Total_3D_Side View 1_850MHz

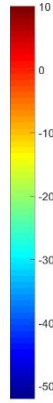
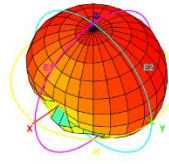

Total_3D_Top View_900MHz

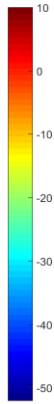
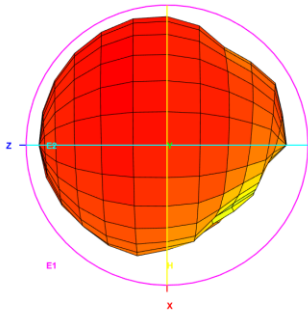

Total_3D_Front View_900MHz

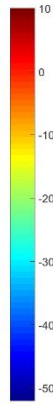
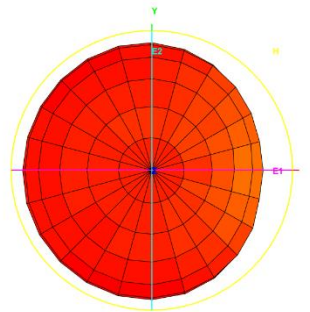

Total_3D_Left View_900MHz

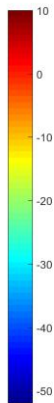
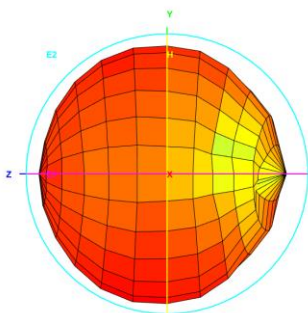

Total_3D_Side View 1_900MHz

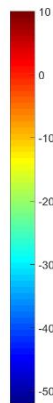
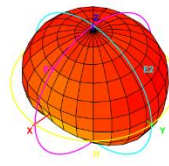

Total_3D_Top View_1.8GHz

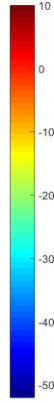
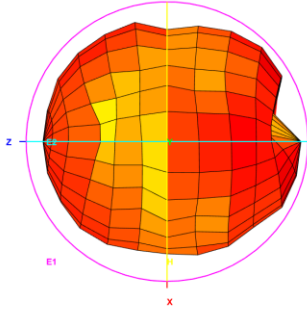

Total_3D_Front View_1.8GHz

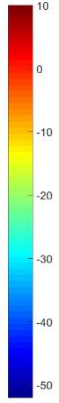
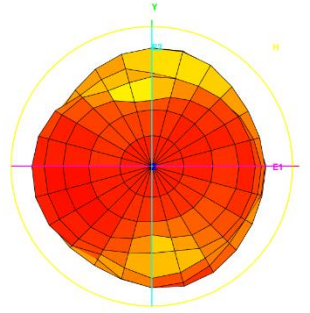

Total_3D_Left View_1.8GHz

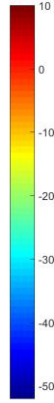
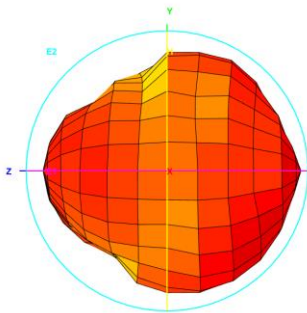

Total_3D_Side View_1.8GHz

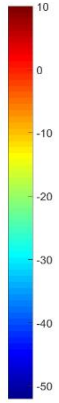
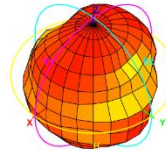

Total_3D_Top View_1.9GHz

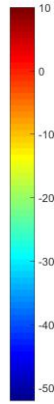
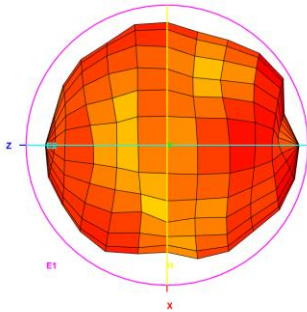

Total_3D_Front View_1.9GHz

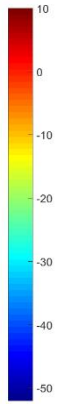
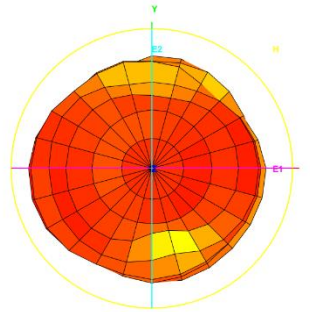

Total_3D_Left View_1.9GHz

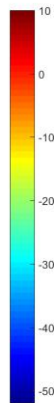
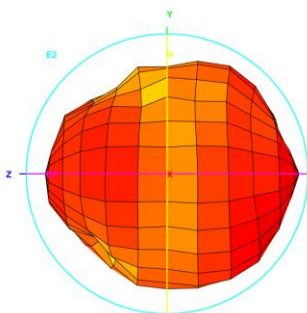

Total_3D_Side View_1.9GHz

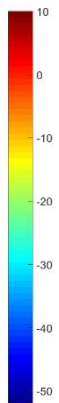
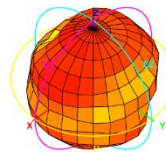

Total_3D_Top View_2.1GHz

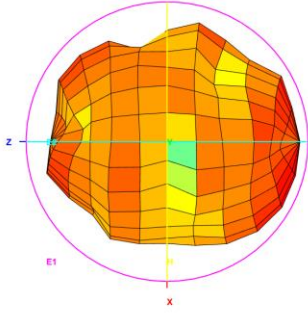

Total_3D_Front View_2.1GHz

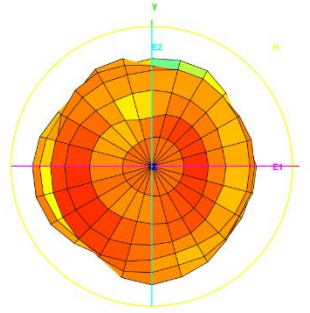

Total_3D_Left View_2.1GHz

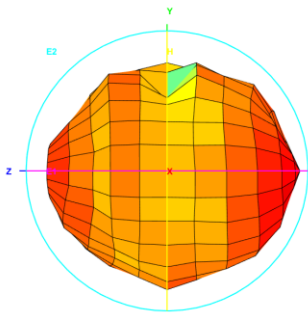

Total_3D_Side View 1_2.1GHz

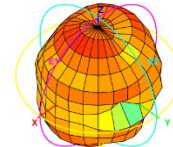

Total_3D_Top View_2.7GHz

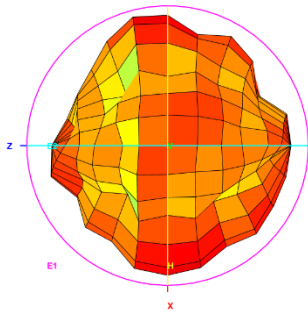

Total_3D_Front View_2.7GHz

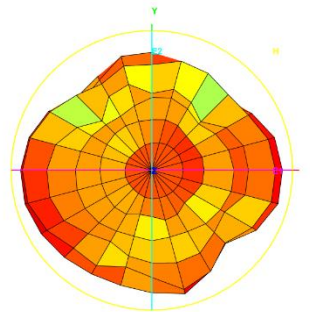

Total_3D_Left View_2.7GHz

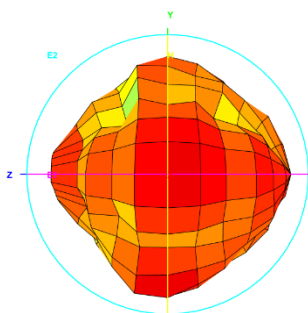

Total_3D_Side View 1_2.7GHz

